

Service Manual

Stereo Cassette Deck

Cassette Deck

RS-DV150

 **DOLBY B NR** *1

Colour
(S) Silver Type

Area
(PP) U.S.A. and
Canada.

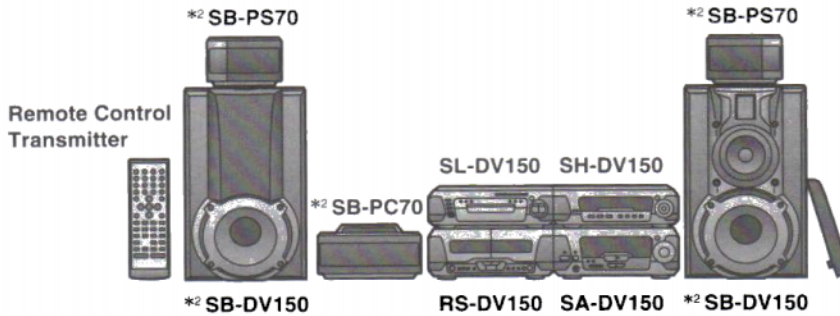

Because of unique interconnecting cables, when a component requires service, send or bring in the entire system.

System	SC-DV150
Sound Processor	SH-DV150
Tuner/Amplifier	SA-DV150
DVD Changer	SL-DV150
Cassette Deck	RS-DV150
Front Speakers*2	SB-DV150
Center Speaker*2	SB-PC70
Surround Speakers*2	SB-PS70

AR-2 MECHANISM SERIES

Specifications

Deck system:	Stereo cassette deck
Track system:	4 track, 2 channel
Recording system:	AC bias
Bias frequency:	100 kHz
Erasing system:	AC erase
Heads:	
Deck 1	
(Playback head);	Permalloy head
Deck 2	
(Recording/Playback head);	Permalloy head
(Erasing head);	Double gap ferrite head
Motors:	
Deck 1, 2	
Capstan drive;	DC servo motor
Tape speed:	4.8 cm/sec (17/8 ips)
Wow and flutter:	0.16 % (WRMS)
Fast forward and rewind times:	Approx. 110 seconds with C-60 cassette tape
Frequency response (Dolby NR off):	
TYPE I (NORMAL);	30 Hz-15 kHz (±3 dB) 20 Hz-17 kHz
TYPE II (HIGH);	30 Hz-15 kHz (±3 dB) 20 Hz-17 kHz
TYPE IV (METAL);	30 Hz-15 kHz (±3 dB) 20 Hz-17 kHz

S/N (Signal level = max recording level, TYPE II type tape):	
NR off;	56 dB (A weighted)
Dolby B NR on;	66 dB (A weighted)
Input sensitivity and impedance:	
REC (IN);	400 mV/23 kΩ
Output voltage and impedance:	
PLAY (OUT);	280 mV/360 Ω
Dimensions (W×H×D):	294×118.5×281 mm (11 ⁹ / ₁₆ "×4 ² / ₃₂ "×11 ¹ / ₁₆ "
Weight:	2.1 kg (4.6 lb.)

- Notes:** Specifications are subject to change without notice.
Weight and dimensions are approximate.
- *1: Dolby noise reduction manufactured under license from Dolby Laboratories Licensing Corporation.
"Dolby" and the double-D symbol  are trade marks of Dolby Laboratories Licensing Corporation.
- *2: Made in Singapore.

⚠ WARNING

This service information is designed for experienced repair technicians only and is not designed for use by the general public. It does not contain warnings or cautions to advise non-technical individuals of potential dangers in attempting to service a product. Products powered by electricity should be serviced or repaired only by experienced professional technicians. Any attempt to service or repair the product or products dealt with in this service information by anyone else could result in serious injury or death.

Panasonic®

© 1999 Matsushita Electric Industrial Co., Ltd.
All rights reserved. Unauthorized copying
and distribution is a violation of law.

■ Contents

	Page		Page
Location of Controls	2	Type Illustration of IC's, Transistors and Diodes	20
Operation Checks and Component Replacement Procedures	3~8	Terminal Function of IC's	21
Service Mode Function of Cassette Mechanism	9,10	Block Diagram	22,23
Schematic Diagram	11~16	Measurements and Adjustments	24~26
Printed Circuit Board Diagram	17~19	Replacement Parts List	27~29
Wiring Connection Diagram	20	Mechanism Parts Location	30,31
		Cabinet Parts Location	32

NOTE:

Refer to the service manual for Model No. SA-DV150 (ORDER No. AD9906141C1) for information on "Accessories", "Connections", "Installation", "Operations" and "Packaging".

■ Location of Controls

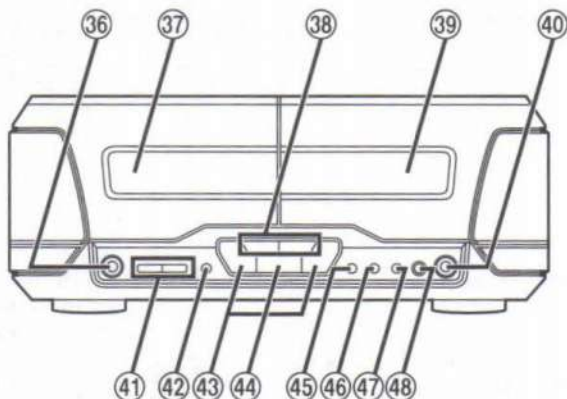

- ③⑥ Deck 1 cassette holder open button (▲ OPEN)
- ③⑦ Deck 1 cassette holder
- ③⑧ Fast forward/rewind buttons (◀◀, ▶▶)
- ③⑨ Deck 2 cassette holder
- ④⑩ Deck 2 cassette holder open button (▲ OPEN)
- ④① Counter reset, display buttons
(COUNTER, RESET, DISPLAY)
- ④② Deck 1/deck 2 select button (DECK 1/2)
- ④③ Playback buttons and indicators (<, >)
The color of the indicators depends on the operation taking place.
If stopped, fast forwarding or rewinding: orange
If playing or recording: green
While carrying out TPS or recording is on Standby: flashes green
- ④④ Stop button (■)
- ④⑤ Dolby noise reduction button (DOLBY NR)
- ④⑥ Reverse mode select button (REV MODE)
- ④⑦ Tape edit button (TAPE EDIT)
- ④⑧ Record pause button (● REC PAUSE)

■ Operation Checks and Component Replacement Procedures

- NOTE**
1. This section describes procedures for checking the operation of the major printed circuit boards and replacing the main components.
 2. For reassembly after operation checks or replacement, reverse the respective procedures. Special reassembly procedures are described only when required.
 3. Select item from the following index when checks or replacement are required.

● Contents

■ Checking Procedures for each P.C.B.		Page.
1. Checking for the main P.C.B..	3.
2. Checking for the operation P.C.B..	3,4.
■ Main Component Replacement Procedures		
1. Replacement for the motor ass'y, capstan belt and winding belt.	5~7.
2. Replacement for the components parts on the mechanism P.C.B..	7.
3. Replacement for the pinch roller ass'y and head block.	7.
4. Replacement for the cassette lid ass'y.	8.
5. Replacement for the cassette holder.	8.

■ Checking Procedures for each P.C.B.

1. Checking for the main P.C.B.

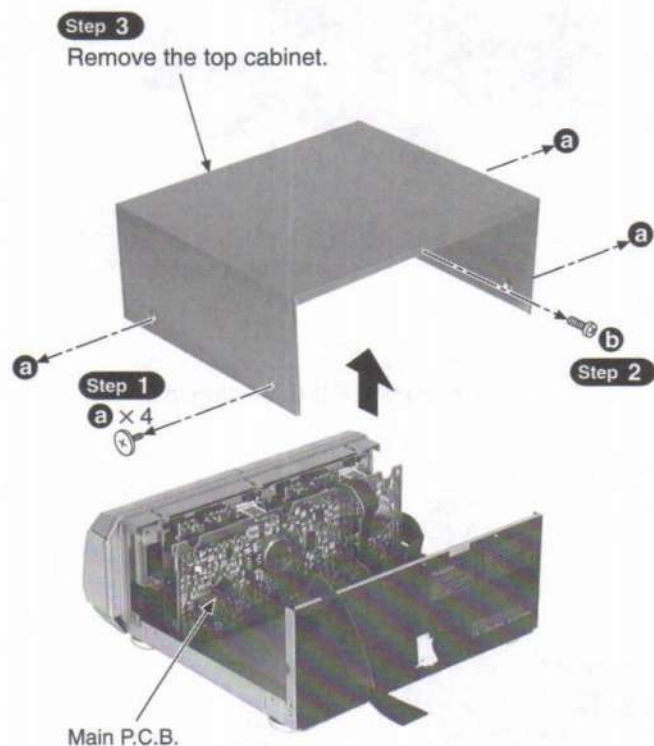

• Check the main P.C.B. as shown above.

2. Checking for the operation P.C.B.

- Follow the **Step 1** ~ **Step 3** of the item 1 in checking procedures for each P.C.B. on page 3.

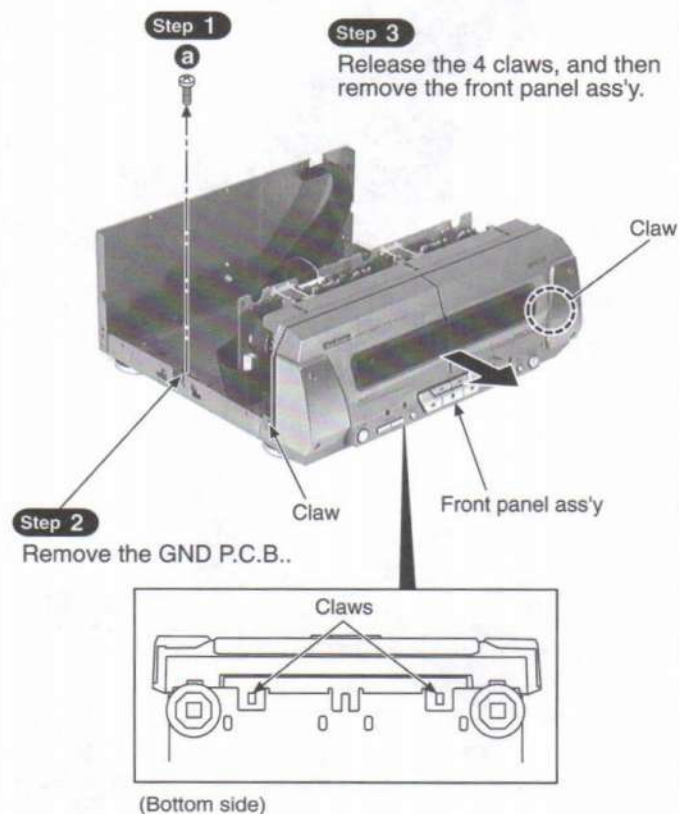

Step 6

Press the eject rod in the direction of arrow, and then open the cassette panel ass'y.

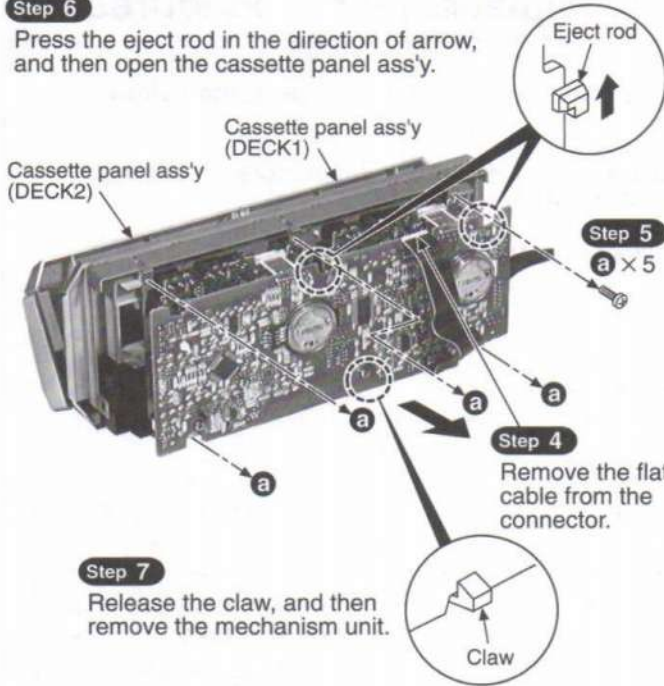

Step 5
a × 5

Step 4

Remove the flat cable from the connector.

Step 7

Release the claw, and then remove the mechanism unit.

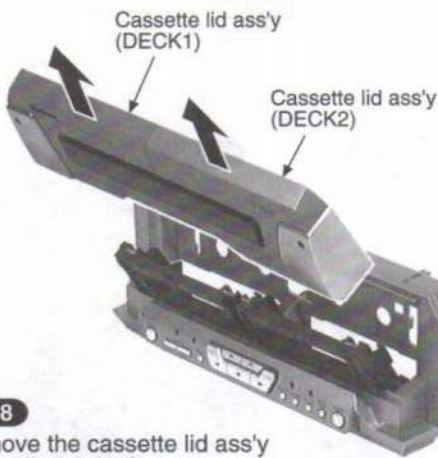
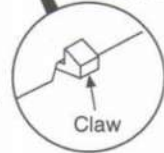

Step 8

Remove the cassette lid ass'y in the direction of arrow.

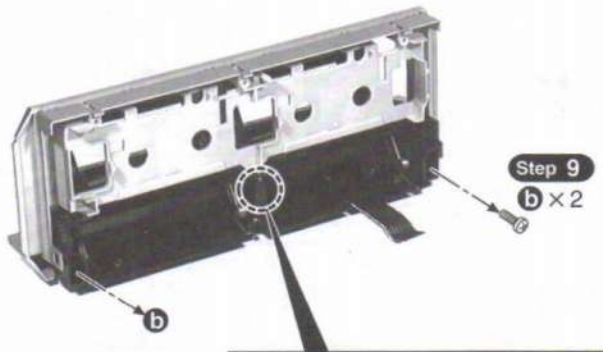

Step 9
b × 2

Step 10

Release the 2 claws, and then remove the deck mecha frame.

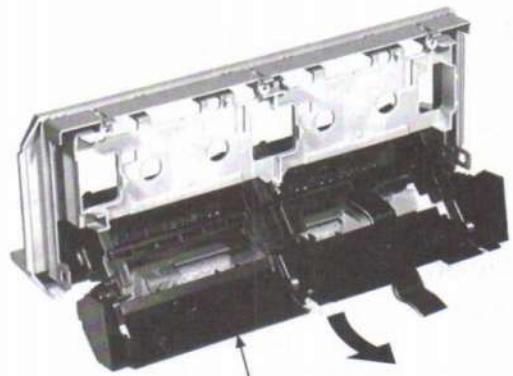
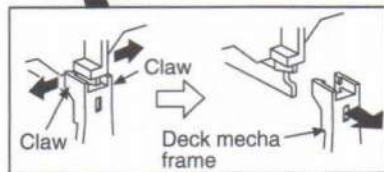

Step 11

Remove the deck mecha frame in the direction of arrow.

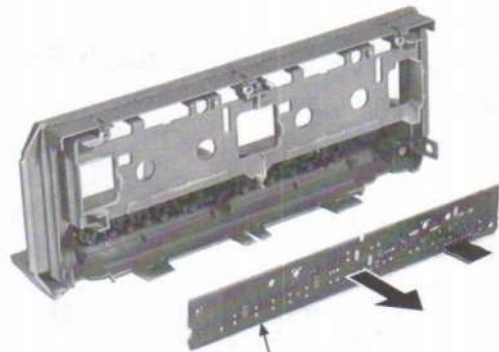

Step 12

Remove the operation P.C.B..

• Check the operation P.C.B. as shown below.

Step 14

Connect the flat cable to the connector (CN901).

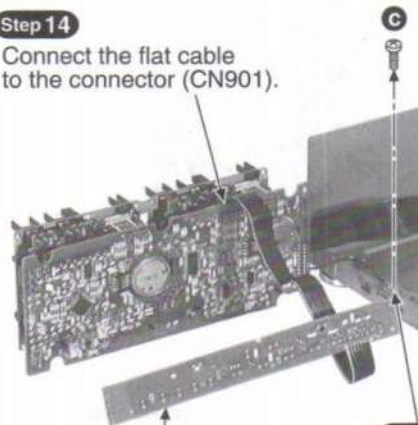

Step 13

Install the GND P.C.B. to the bottom chassis, and then tighten screw (c).

Operation P.C.B.

■ Main Component Replacement Procedures

1. Replacement for the motor ass'y, capstan belt and winding belt

- Follow the **Step 1** ~ **Step 3** of the item 1 in checking procedures for each P.C.B. on page 3.
- Follow the **Step 1** ~ **Step 7** of the item 2 in checking procedures for each P.C.B. on pages 3 and 4.

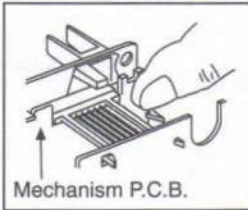

NOTE

When removing the main P.C.B., remove it with holding the mechanism P.C.B..

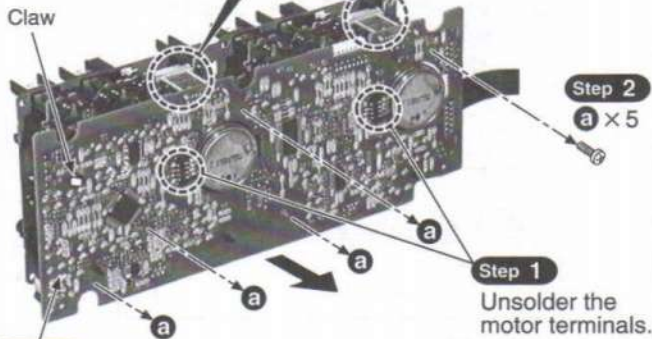

NOTE

Handle the connector with care so that the shape of terminals different from others.

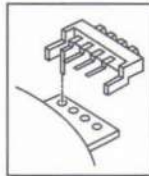

※ The illustration below shows DECK2 mechanism. For DECK1 mechanism, perform the same procedure as DECK2.

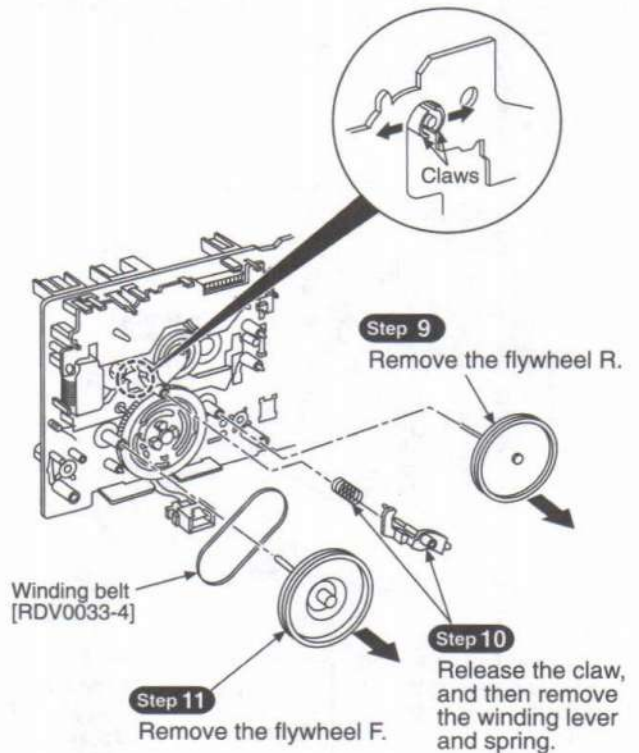
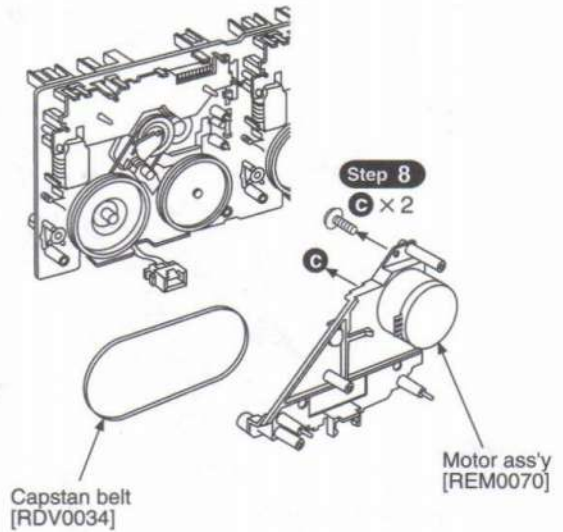
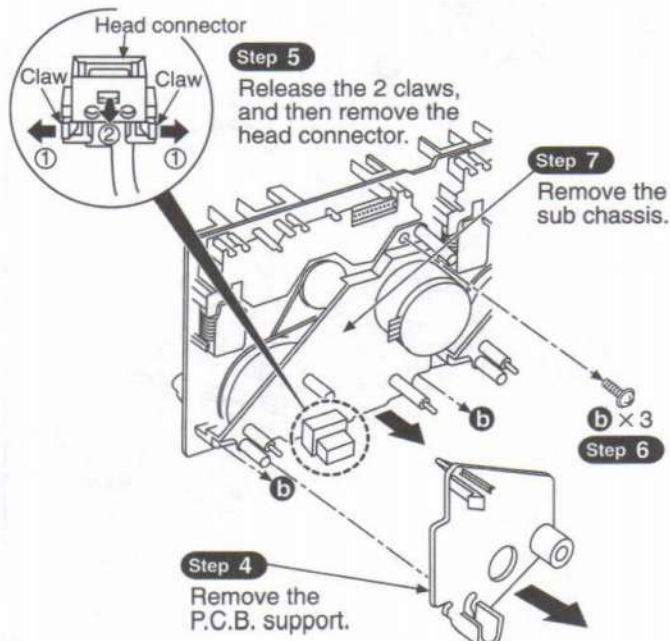

Installation of the belt

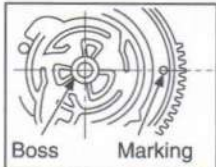

Step 1
The boss and marking should be positioned horizontally.

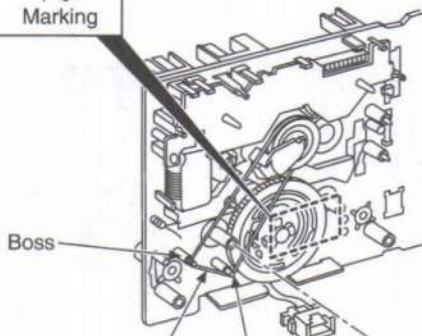

Step 2
Put the winding belt on the pulley temporarily.

Step 3
Install the flywheel F.

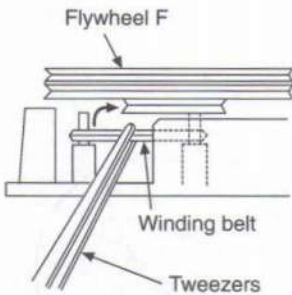

Step 4
Put the winding belt on the flywheel F.

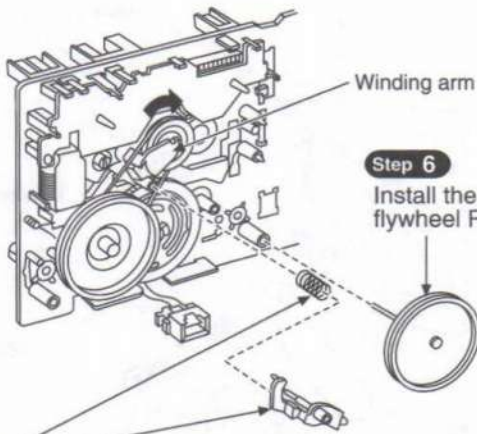

Step 5
Install the winding lever and spring while pressing the winding arm in the direction of arrow.
(The winding lever must be inserted completely and latched with claws.)

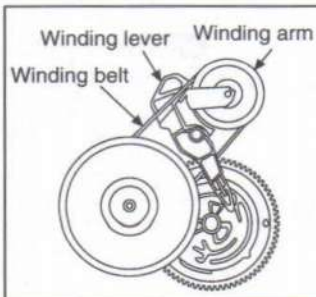

NOTE
The winding lever should be positioned as shown right.

Step 7
Put the capstan belt temporarily as shown below.

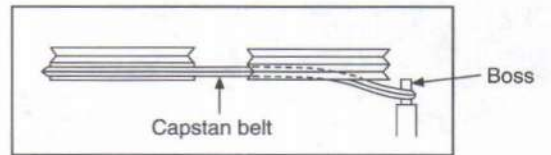
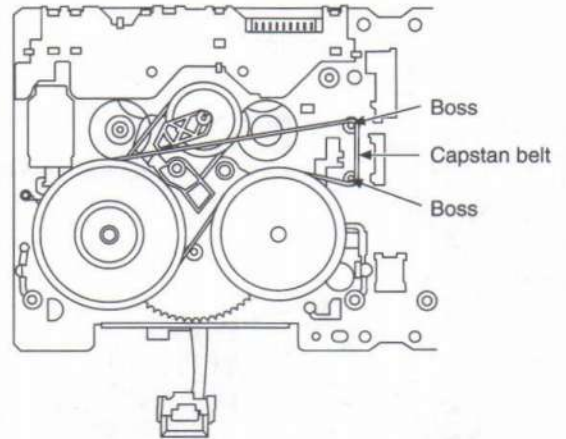

(Side view)

Step 8
Install the sub chassis to the mechanism, and then tighten screws.

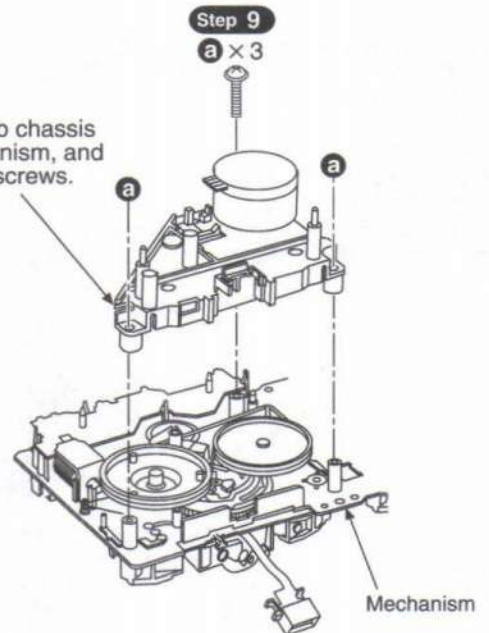

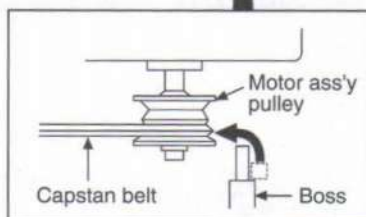
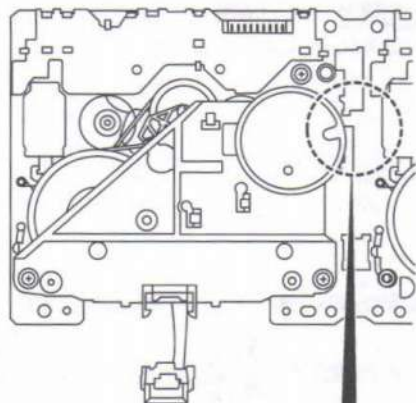
**Step 10**

Put the capstan belt on the motor ass'y pulley.

2. Replacement for the components parts on the mechanism P.C.B.

- Follow the **Step 1** ~ **Step 3** of the item 1 in checking procedures for each P.C.B. on page 3.
- Follow the **Step 1** ~ **Step 5** of the item 2 in checking procedures for each P.C.B. on pages 3 and 4.
- Follow the **Step 1** ~ **Step 4** of the item 1 in main component replacement procedures on page 5.

※ The mechanism as shown below is for DECK2.
For the one of DECK1, perform the same procedures.

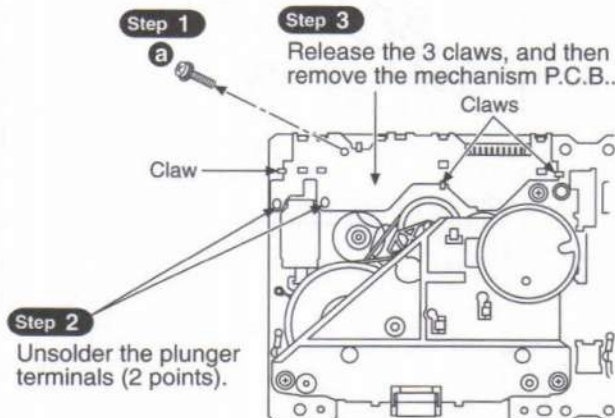

3. Replacement for the pinch roller ass'y and head block

- Follow the **Step 1** ~ **Step 3** of the item 1 in checking procedures for each P.C.B. on page 3.
- Follow the **Step 1** ~ **Step 5** of the item 2 in checking procedures for each P.C.B. on pages 3 and 4.
- Follow the **Step 1** ~ **Step 5** of the item 1 in main component replacement procedures on page 5.

※ The mechanism as shown below is for DECK2.
For the one of DECK1, perform the same procedures.

Step 1

Release the 2 claws, and then remove the pinch roller (R), (F).

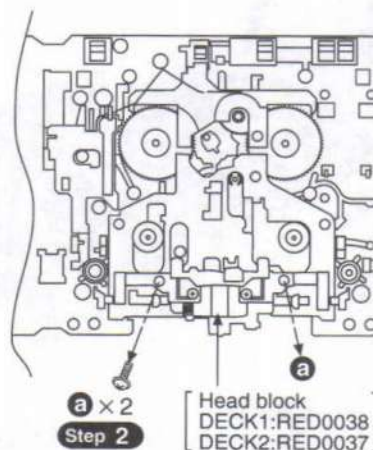
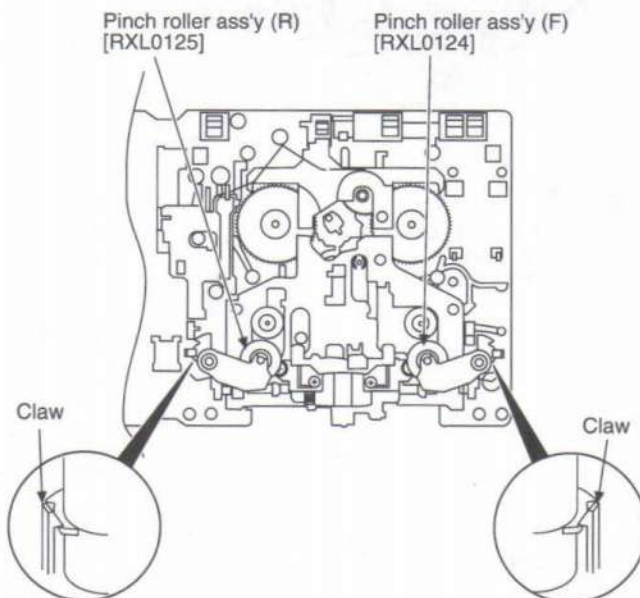

4. Replacement for the cassette lid ass'y

- Follow the **Step 1** ~ **Step 3** of the item 1 in checking procedures for each P.C.B. on page 3.

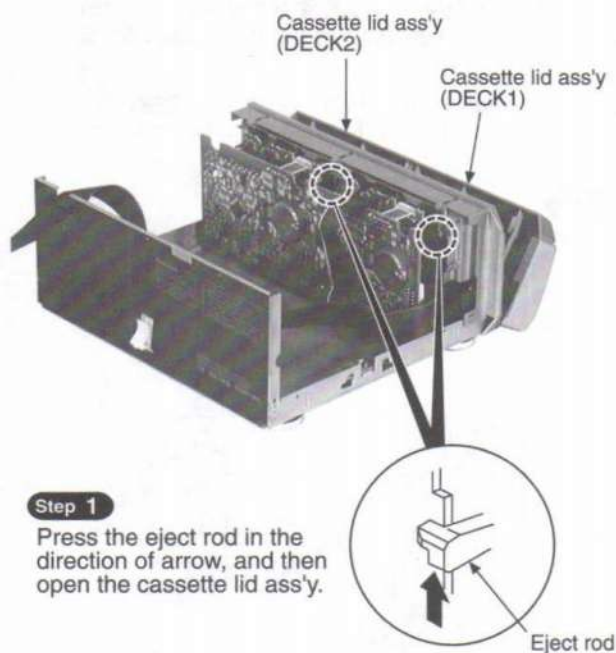

Step 1

Press the eject rod in the direction of arrow, and then open the cassette lid ass'y.

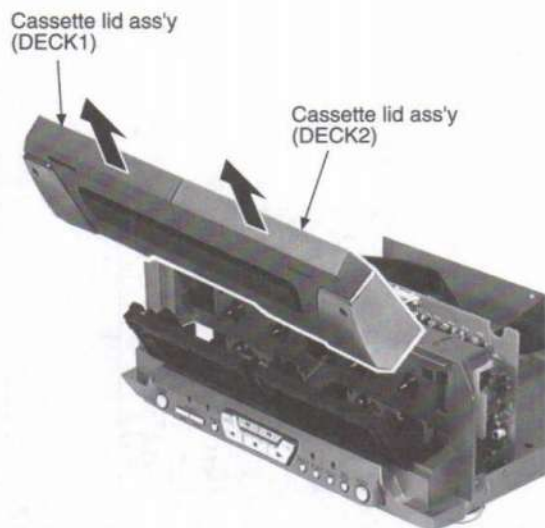

Step 2

Remove the cassette lid ass'y in the direction of arrow.

5. Replacement for the cassette holder

- Follow the **Step 1** ~ **Step 3** of the item 1 in checking procedures for each P.C.B. on page 3.
- Follow the **Step 1** ~ **Step 9** of the item 2 in checking procedures for each P.C.B. on pages 3 and 4.

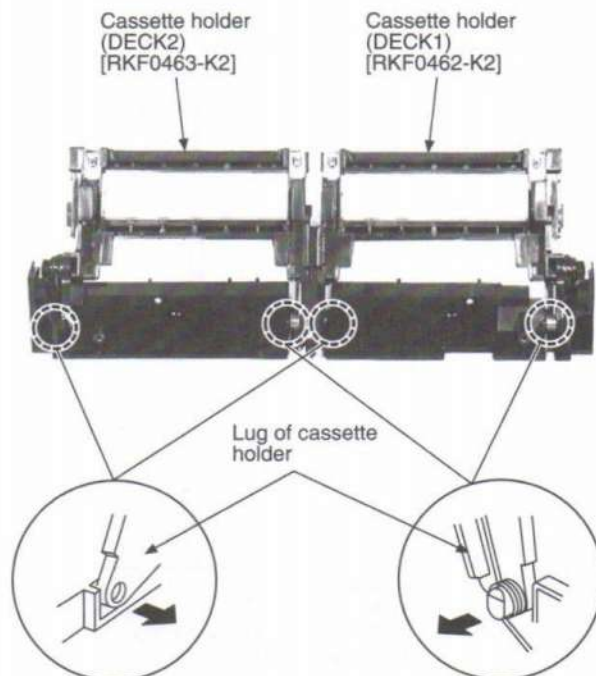

- Release the lug of cassette holder in the direction of arrow.

■ Open spring installation

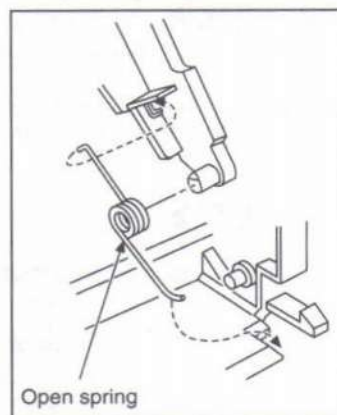

■ Service Mode Function of Cassette Mechanism

This unit is equipped with a service mode function of cassette mechanism. Use this function during maintenance to check faults of the items below.

● Cassette tapes to be prepared

- Metal tape: Recorded music tape with only one erasure-prevention tab intact (use middle portion of tape).
- Normal tape: Recorded music tape with both erasure-prevention tabs intact
- CrO₂ tape: (use middle portion of tape).

● Selecting Service Mode

1. Turn on the power to the unit.
2. Check that no tape is inserted in the cassette deck. (Service mode cannot be selected with a tape inserted in the cassette deck.)
Press the DOLBY NR button for about 2 seconds, and keep pressing it, also press the STOP button for about 2 seconds. (Refer to Fig. 1.)
3. The LED indicator for Direction goes out, the service mode has been activated.

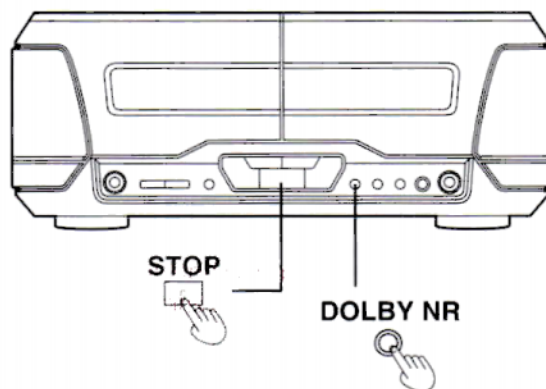

Fig. 1

● Deck 1 Mechanism Check

Use the Deck 1/2 select button to change the flashing Deck 2 indicator to Deck 1. (No change required if Deck 1 indicator already flashing.)

DECK 1/2



Open the Deck 1 cassette holder. (OPEN button)



Insert a CrO₂ tape into the Deck 1 and close the cassette holder.



Press the TPS button. (Tape fast forwards for about 2 seconds then stops.)

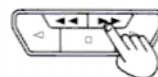

Press the PLAY button. (After TPS operation and check, the tape stops.)

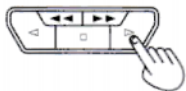

Open the Deck 1 cassette holder and replace the tape with a normal tape. (OPEN button)



Close the Deck 1 cassette holder.

Press the REC/PAUSE button. (No record operation.)



Press the STOP button. A mechanism error code is displayed. (Refer to Table 1.)

Each time the STOP button is pressed, the fault items are displayed in sequence.

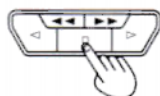

● Table 1

FL display	Symptom	Cause
H01	Cassette deck does not operate correctly.	Faulty cassette deck mechanism mode detection switch (Deck 1: S951, Deck 2: S971) and plunger. (Check and replace)
H02	Unit does not record, or the unit goes into recording mode even when the erasure-prevention tabs have been removed from the cassette.	Faulty erasure-prevention tab detection switch (S974, S975) or short-circuit. (Check and replace)
H03	Tape does not play, even when the tape deck play button is pressed. The motor operates when the tape deck play button is pressed, even when no cassette is loaded in the deck.	Faulty tape detection switch (Deck 1: S952, Deck 2: S972) or short-circuit. (Check and replace)
H06	Cassette deck does not detect CrO ₂ tape.	Faulty CrO ₂ tape detect switch. (S973) (Check and replace)
H07	Cassette deck does not detect Metal tape.	Faulty Metal tape detect switch. (S976) (Check and replace)
F01	When the tape PLAY button is pressed, tape advances only slightly and then stops.	Reel pulse error. (Faulty Hall IC) (Check and replace)
F02	TPS (tape program search) does not work.	Faulty TPS signal detection or faulty plunger control. (Check and replace mechanism control IC)

● Deck 2 Mechanism Check

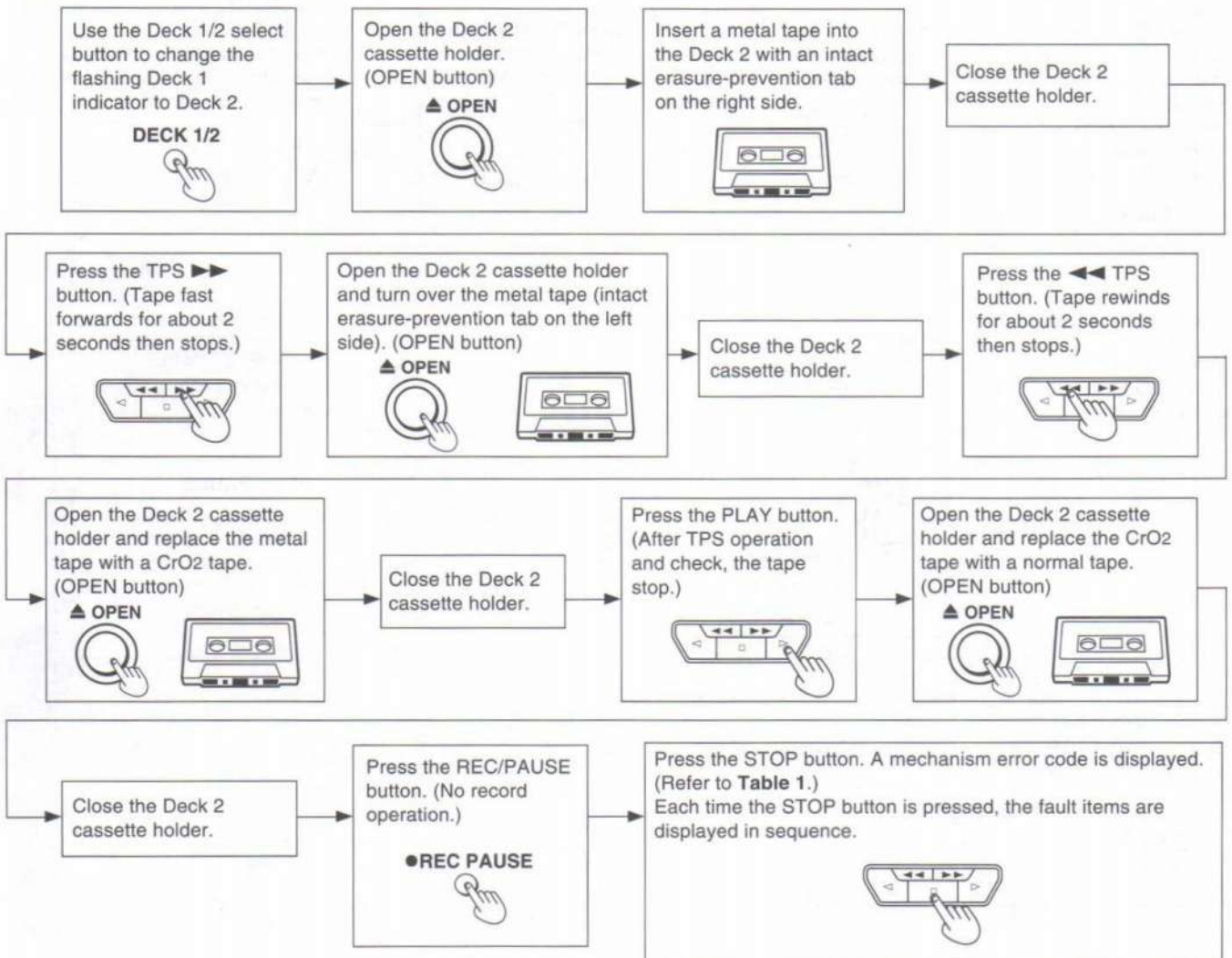

● Exiting Self-Check Mode

1. Press the STOP button for more than 5 seconds. (Diagnostic contents stored in memory for both Deck 1 and 2 are erased.)
2. Remove the cassette tape from the cassette holder.
3. Turn off the unit.



Schematic Diagram

	Page		Page
A MAIN CIRCUIT	12~16	D EARTH TERMINAL CIRCUIT	15
B MECHANISM CIRCUIT (DECK1)	14	E OPERATION CIRCUIT	16
C MECHANISM CIRCUIT (DECK2)	14		

- This schematic diagram may be modified at any time with the development of new technology.

Notes:

- **S900** : Stop switch (■)
- **S901** : DECK 2 cassette holder open switch (▲ OPEN)
- **S903** : Tape edit switch (TAPE EDIT)
- **S904** : Record pause switch (● REC PAUSE)
- **S905** : Dolby noise reduction switch (DOLBY NR)
- **S906** : Fast forward switch (▶▶)
- **S907** : Forward side playback switch (▷)
- **S909** : Reverse side playback switch (◁)
- **S910** : Rewind switch (◀◀)
- **S911** : Reverse mode select switch (REV MODE)
- **S912** : DECK 1/DECK 2 select switch (DECK 1/2)
- **S913** : Counter display switch (COUNTER DISPLAY)
- **S914** : Counter reset switch (COUNTER RESET)
- **S915** : DECK 1 cassette holder open switch (▲ OPEN)
- **S951** : DECK 1 mode detect switch
- **S952** : DECK 1 half detect switch
- **S953** : DECK 1 CrO₂ tape detect switch
- **S971** : DECK 2 mode detect switch
- **S972** : DECK 2 half detect switch
- **S973** : DECK 2 CrO₂ tape detect switch
- **S974** : DECK 2 reverse side record prevention tab detect switch
- **S975** : DECK 2 forward side record prevention tab detect switch
- **S976** : DECK 2 METAL tape detect switch
- **VR101** : DECK 1 Playback gain adjustment VR (R-ch)
- **VR102** : DECK 2 Playback gain adjustment VR (L-ch)
- **VR103** : DECK 2 Playback gain adjustment VR (R-ch)
- **VR104** : DECK 1 Playback gain adjustment VR (L-ch)
- **VR801** : DECK 1 tape speed adjustment VR (normal)
- **VR803** : DECK 2 tape speed adjustment VR (normal)

- Indicated voltage values are the standard values for the unit measured by the DC electronic circuit tester (high-impedance) with the chassis taken as standard. Therefore, there may exist some errors in the voltage values, depending on the internal impedance of the DC circuit tester.

No mark : Playback () : Recording

- Important safety notice:

Components identified by ▲ mark have special characteristics important for safety.

Furthermore, special parts which have purposes of fire-retardant (resistors), high-quality sound (capacitors), low-noise (resistors), etc. are used. When replacing any of components, be sure to use only manufacturer's specified parts shown in the parts list.

- **Caution!**

IC and LSI are sensitive to static electricity.

Secondary trouble can be prevented by taking care during repair.

Cover the parts boxes made of plastics with aluminum foil.

Ground the soldering iron.

Put a conductive mat on the work table.

Do not touch the legs of IC or LSI with the fingers directly.

- **Voltage and signal line**

 : Positive voltage line

 : Playback signal line

 : Recording signal line

A MAIN CIRCUIT

➔ : PLAYBACK SIGNAL LINE
 ➔ : POSITIVE VOLTAGE LINE
 ⇨ : RECORDING SIGNAL LINE

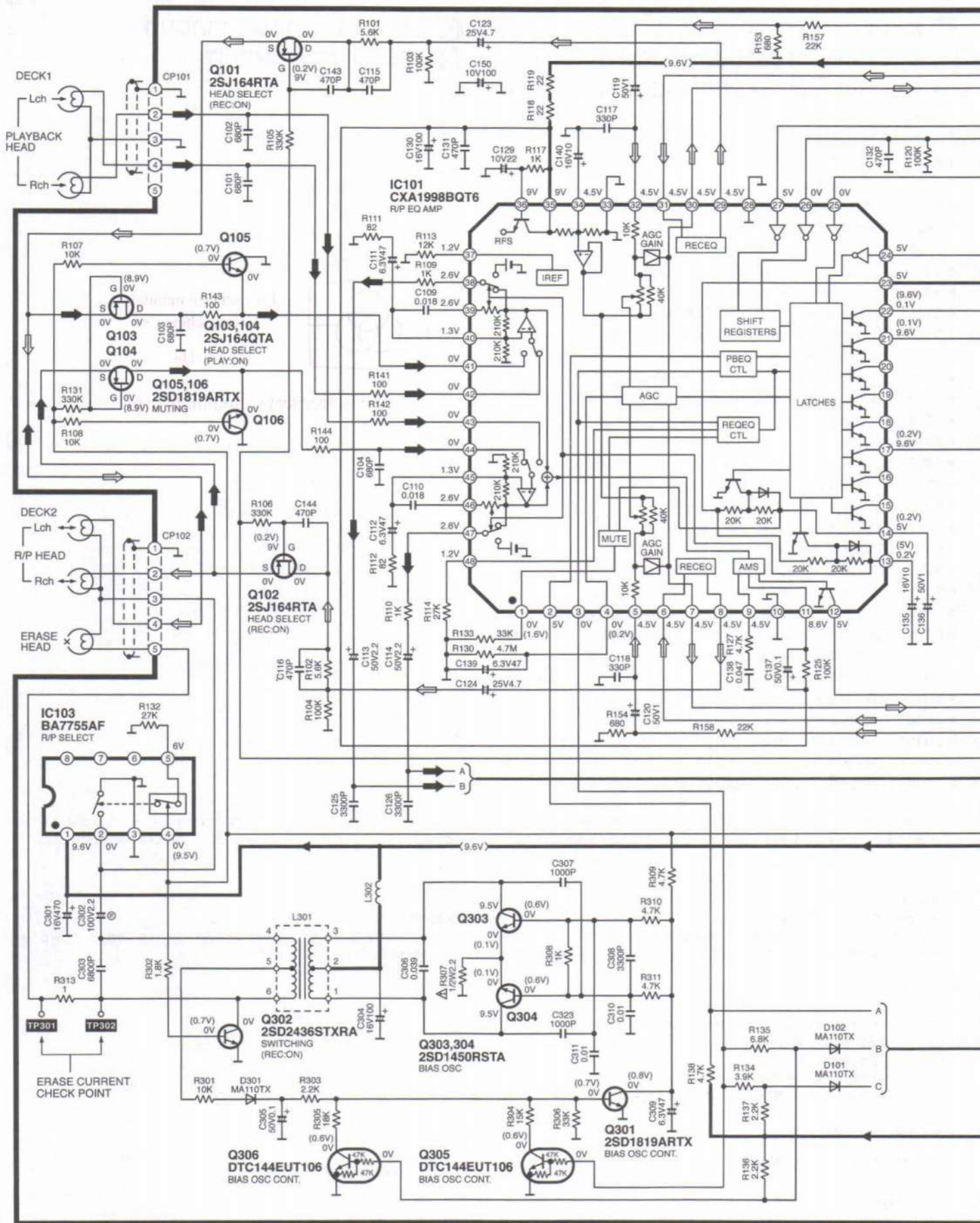

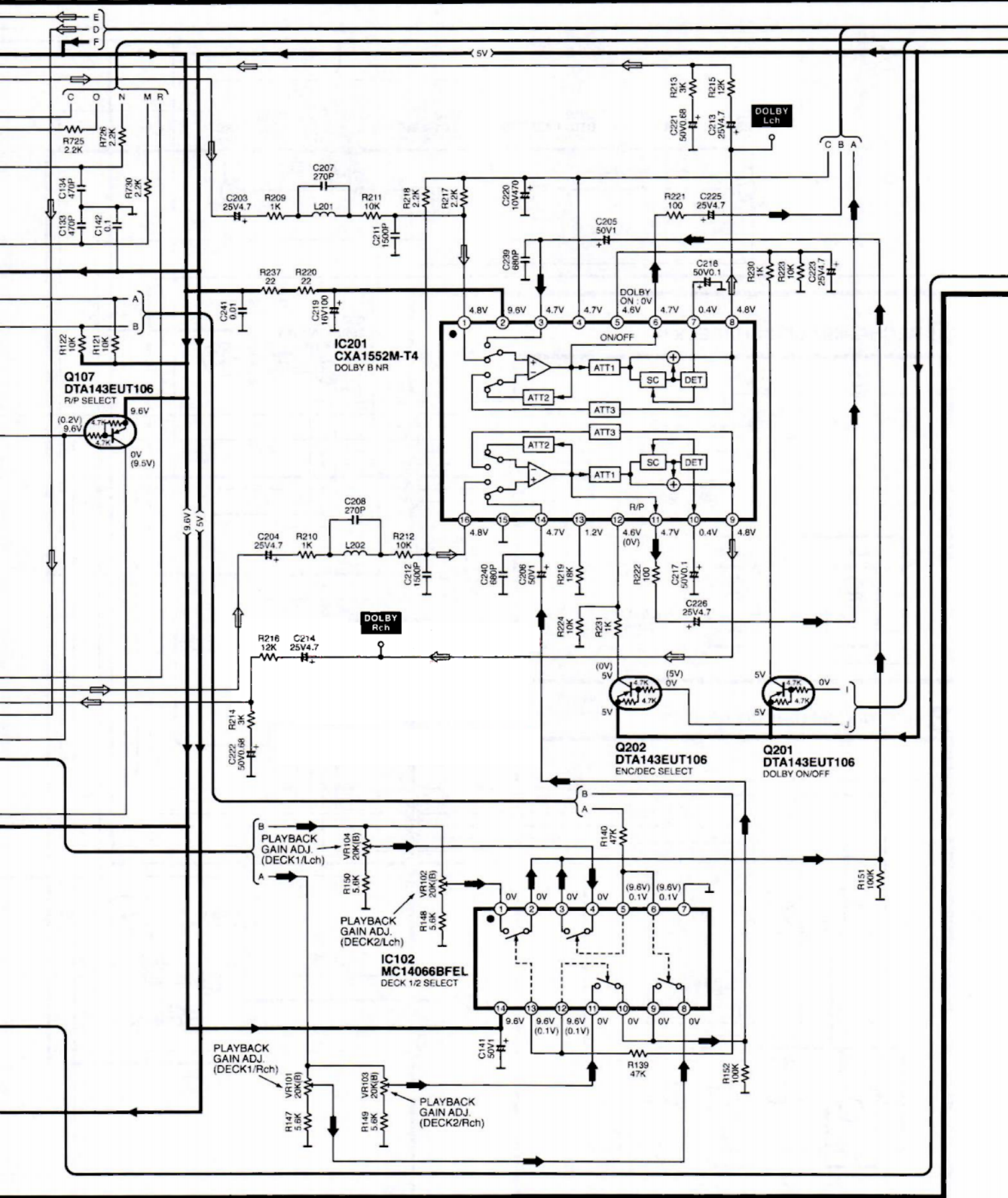

A MAIN CIRCUIT

→ POSITIVE VOLTAGE LINE

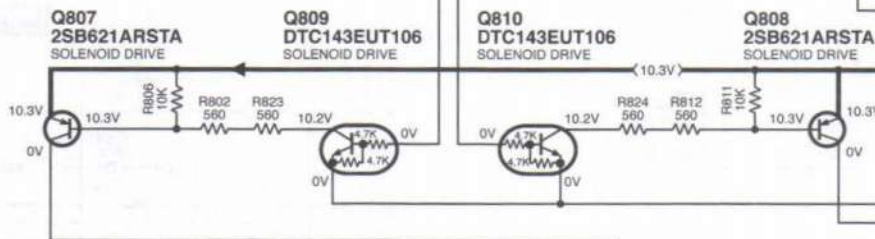

B MECHANISM CIRCUIT (DECK1)

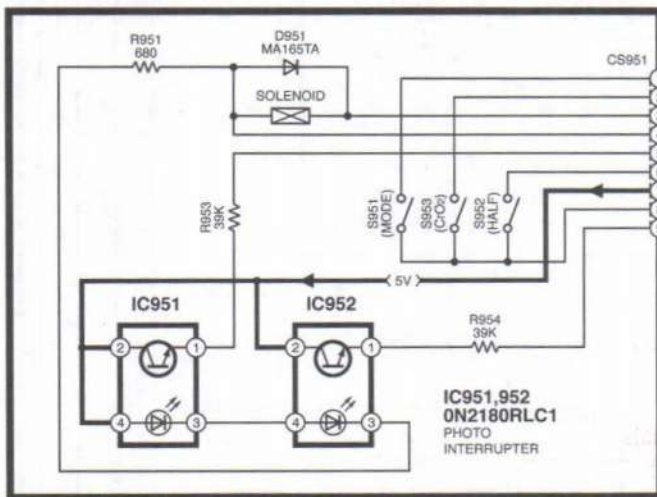

C MECHANISM CIRCUIT (DECK2)

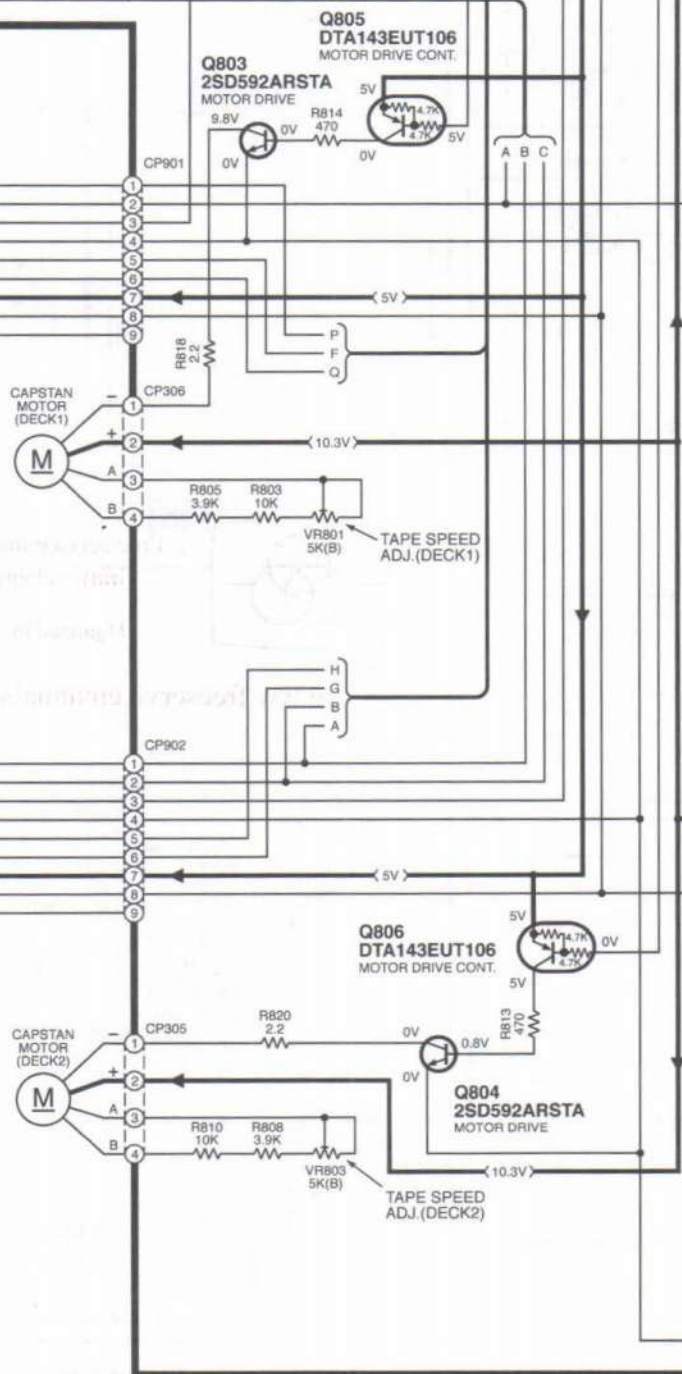
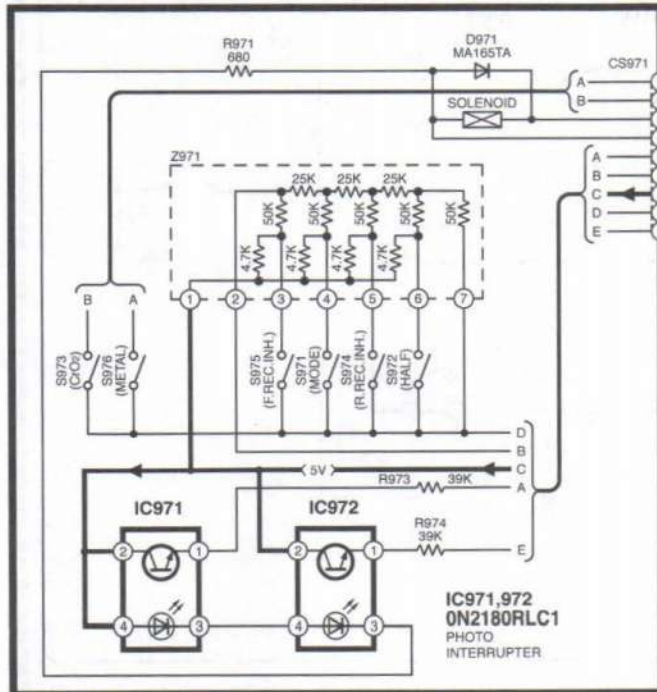

 : PLAYBACK SIGNAL LINE
 : POSITIVE VOLTAGE LINE
 : RECORDING SIGNAL LINE

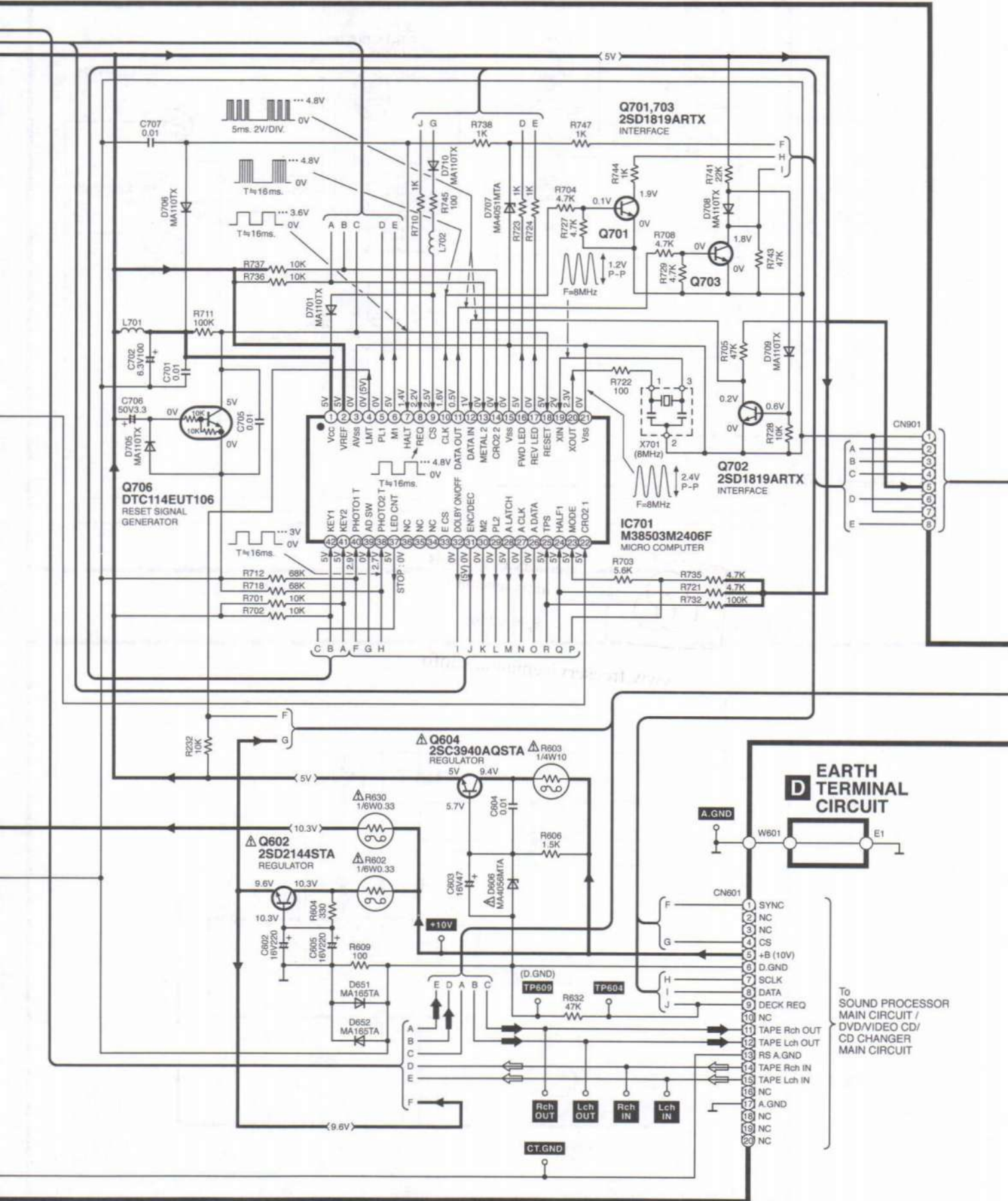

E OPERATION CIRCUIT

→ : POSITIVE VOLTAGE LINE
 ⇨ : PLAYBACK SIGNAL LINE

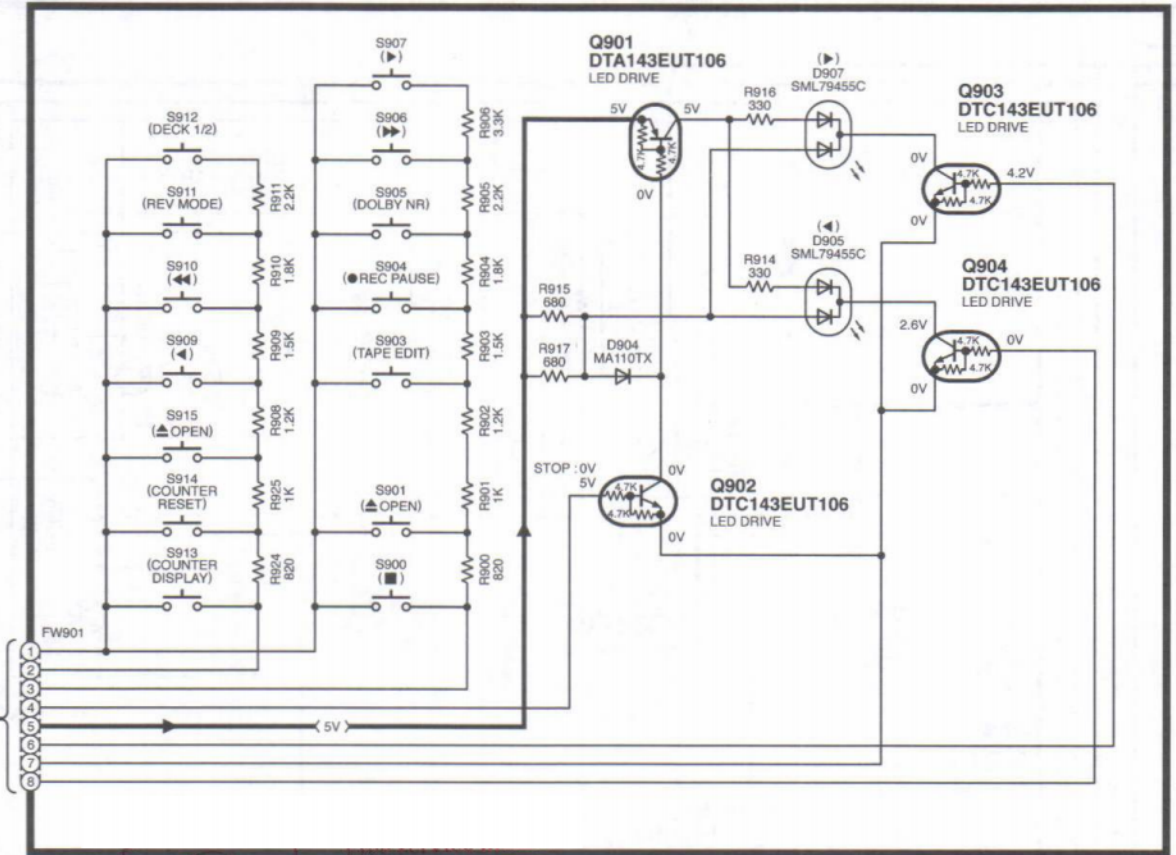

A MAIN CIRCUIT

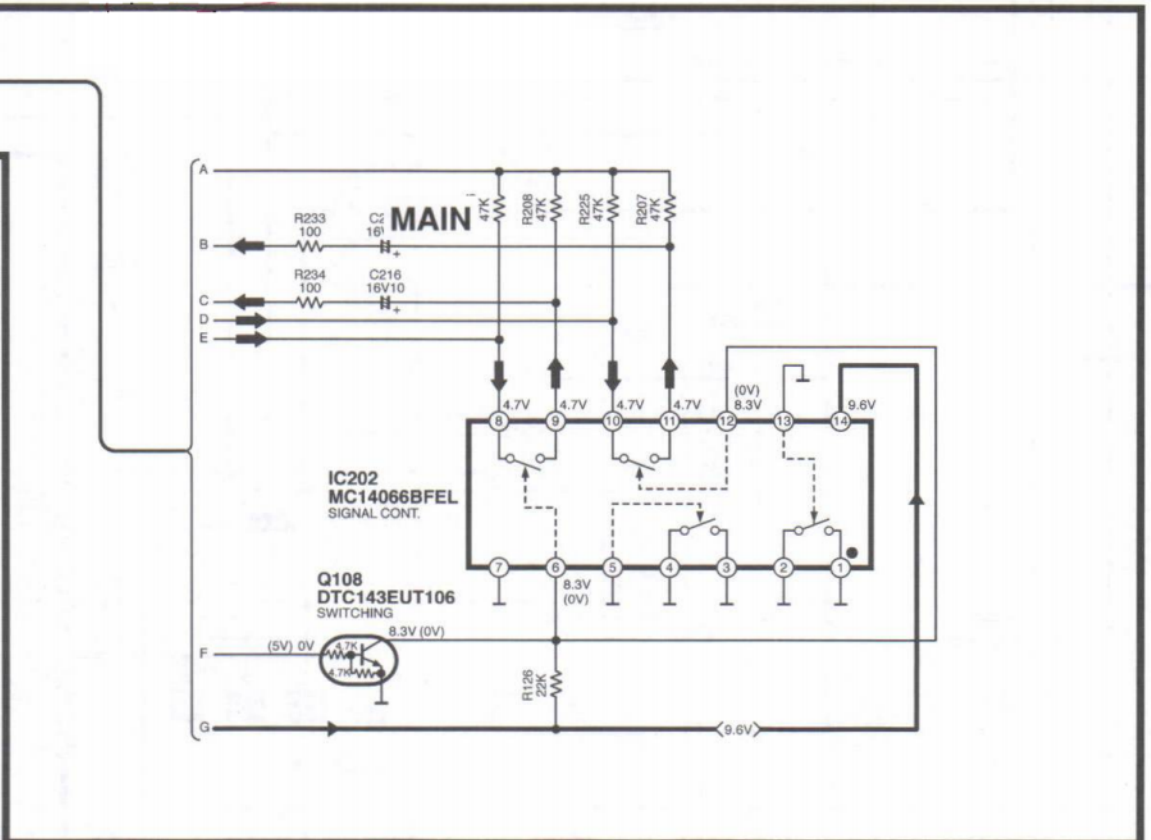

Printed Circuit Board Diagram

This printed circuit board diagram may be modified at any time with the development of new technology.

A MAIN P.C.B.

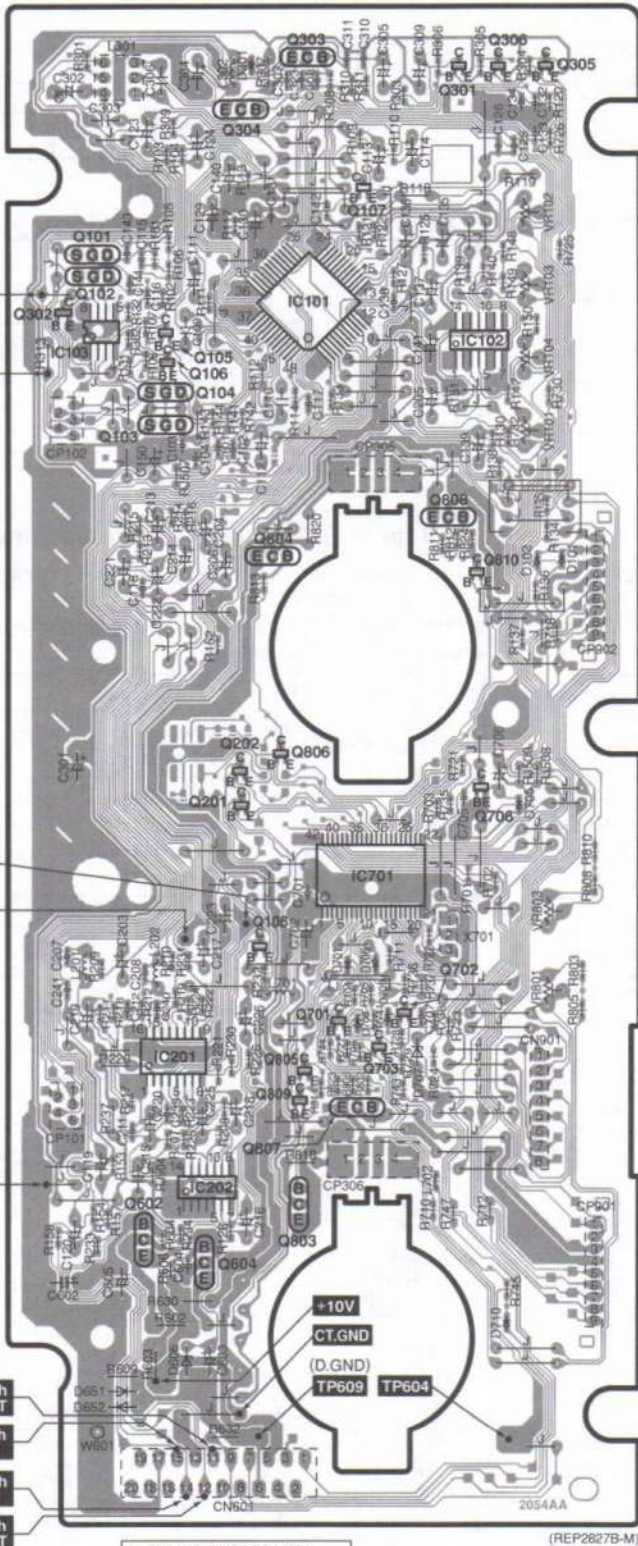

ELECTRICAL PARTS LOCATION

Ref. No.	Lo. No.	Ref. No.	Lo. No.	Ref. No.	Lo. No.	Ref. No.	Lo. No.
A MAIN P.C.B.							
IC101	2C	R101	2B	R302	3B	C114	2C
IC102	3C	R102	2B	R303	1C	C115	2B
IC103	3B	R103	2B	R304	1D	C116	2B
IC201	6B	R104	2B	R305	1C	C117	3C
IC202	6B	R105	2B	R306	1C	C118	4B
IC701	5C	R106	2B	R307	1B	C119	6B
Q101	2B	R107	3B	R308	1C	C120	7B
Q102	2B	R108	3B	R309	2B	C123	2B
Q103	3B	R109	2C	R310	1C	C124	2B
Q104	3B	R110	2C	R311	1C	C125	2D
Q105	3B	R111	2B	R313	3A	C126	2C
Q106	3B	R112	3B	R602	7B	C129	2B
Q107	2C	R113	2B	R603	7B	C130	2B
Q108	5B	R114	3C	R604	7B	C131	2B
Q201	5B	R117	2B	R606	7B	C132	2D
Q202	5B	R118	2C	R609	7B	C133	2D
Q301	1C	R119	2D	R630	7B	C134	2D
Q302	2A	R120	2D	R632	8B	C135	2C
Q303	1C	R121	2C	R701	5C	C136	2C
Q304	2B	R122	2C	R702	5C	C137	2C
Q305	1D	R125	2C	R703	5C	C138	2C
Q306	1C	R126	7B	R704	6C	C139	3C
Q602	7B	R127	2C	R705	6C	C140	2B
Q604	7B	R130	3C	R708	6C	C141	3C
Q701	6C	R131	3B	R710	7C	C142	2C
Q702	6C	R132	2B	R711	5C	C143	2B
Q703	6C	R133	3C	R712	7C	C144	2B
Q706	5C	R134	3D	R718	4D	C150	3B
Q803	7C	R135	3D	R721	5C	C203	5B
Q804	4B	R136	4D	R722	5C	C204	3B
Q805	6C	R137	4D	R723	6C	C205	3C
Q806	4B	R138	3C	R724	6C	C206	4B
Q807	6C	R139	2C	R725	2D	C207	5B
Q808	3C	R140	2C	R726	2D	C208	5B
Q809	6C	R141	3B	R727	6C	C211	6B
Q810	4C	R142	3B	R728	6C	C212	6B
D101	4D	R143	3B	R729	6C	C213	3B
D102	4D	R144	3B	R730	3D	C214	4B
D301	1B	R147	3D	R732	3D	C215	6B
D606	7B	R148	2C	R735	5C	C216	7B
D651	7B	R149	2C	R736	6C	C217	5B
D652	7B	R150	3D	R737	6C	C218	6B
D701	5C	R151	3C	R738	6C	C219	6B
D705	5D	R152	4B	R741	6C	C220	6B
D706	5C	R153	6B	R743	6C	C221	4B
D707	6C	R154	7B	R744	6C	C222	4B
D708	6C	R157	7B	R745	7D	C223	5B
D709	6C	R158	7A	R747	7C	C225	6B
D710	7C	R207	6B	R802	6C	C226	6B
VR101	3D	R208	6B	R803	5D	C239	6B
VR102	2D	R209	5B	R805	6D	C240	6B
VR103	2D	R210	5B	R806	6C	C241	6B
VR104	3D	R211	6B	R808	5D	C301	5B
VR801	6D	R212	6B	R810	5D	C302	1B
VR803	5D	R213	4B	R811	4C	C303	2B
L201	5B	R214	3B	R812	4C	C304	1B
L202	5B	R215	3B	R813	4B	C305	1C
L301	1B	R216	3B	R814	6C	C306	1B
L302	1B	R217	6B	R818	6C	C307	1B
L701	6B	R218	6B	R820	3C	C308	1C
L702	6C	R219	6B	R823	6C	C309	1C
X701	5C	R220	6B	R824	4C	C310	1C
CN601	8B	R221	6B	RJ504	6B	C311	1C
CN901	6D	R222	6B	RJ507	3B	C323	1C
CP101	6B	R223	6B	RJ508	5D	C602	7B
CP102	3B	R224	6B	RJ509	5D	C603	7B
CP305	3C	R225	6B	C101	3B	C604	7B
CP306	6C	R226	6B	C102	3B	C605	7B
CP901	7D	R230	6B	C103	3B	C701	5C
CP902	4D	R231	5B	C104	3B	C702	5C
W601	8B	R232	6B	C109	3B	C705	5C
TP301	3A	R233	7B	C110	3B	C706	5C
TP302	2A	R234	7B	C111	2B	C707	6C
TP604	8D	R237	6B	C112	3B		
TP609	8B	R301	1B	C113	2C		

To SOUND PROCESSOR/
DVD/VIDEO CD/CD CHANGER

(REP2827B-M)



ELECTRICAL PARTS LOCATION

Ref. No.	Lo. No.	Ref. No.	Lo. No.	Ref. No.	Lo. No.	Ref. No.	Lo. No.	Ref. No.	Lo. No.	Ref. No.	Lo. No.	Ref. No.	Lo. No.	Ref. No.	Lo. No.
MECHANISM P.C.B. (DECK 1)															
IC951	3B	D951	3A	S952	3B	S953	3A	CS951	3C	R951	3C	R953	3A	R954	3C
IC952	3C	S951	3B												
MECHANISM P.C.B. (DECK 2)															
IC971	3E	D971	3D	S971	3E	S973	3D	S975	3F	CS971	3F	R973	3D	R974	3F
IC972	3F	Z971	3E	S972	3E	S974	3D	S976	3E	R971	3F				

B MECHANISM P.C.B. (DECK1)

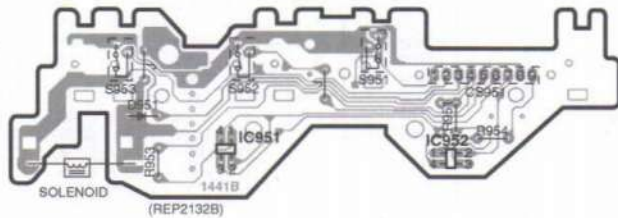

C MECHANISM P.C.B. (DECK2)

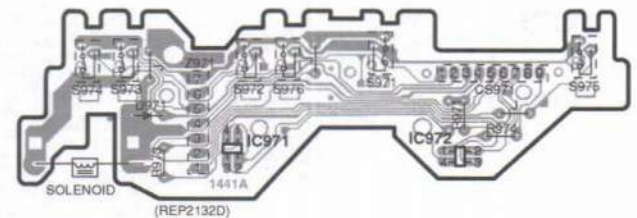

Note for IC951 and IC952 replacement

- Two different types (old or new) parts are mounted on P.C.B. as for IC951 and 952.
- When servicing, care to replace the parts due to those shape.
- Replacement procedures

Note for IC971 and IC972 replacement

- Two different types (old or new) parts are mounted on P.C.B. as for IC971 and 972.
- When servicing, care to replace the parts due to those shape.
- Replacement procedures

	Parts No.	Direction	Remarks
Old	0N2180RLC	Mount the parts on given position. (Printed pattern on P.C.B.)	Refer to the figure below.
New	0N2180RLC1	For IC951: Mount the parts so the cut corner is located upper right. For IC952: Mount the parts so the cut corner is located lower right.	

	Parts No.	Direction	Remarks
Old	0N2180RLC	Mount the parts on given position. (Printed pattern on P.C.B.)	Refer to the figure below.
New	0N2180RLC1	For IC971: Mount the parts so the cut corner is located upper right. For IC972: Mount the parts so the cut corner is located lower right.	

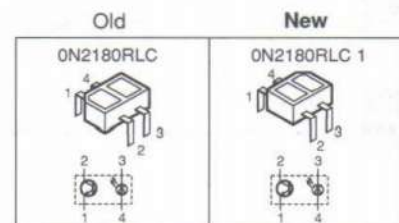
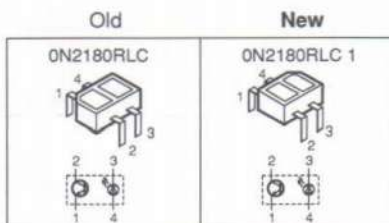
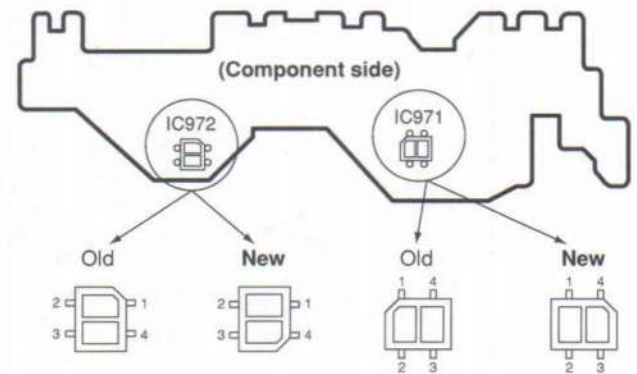
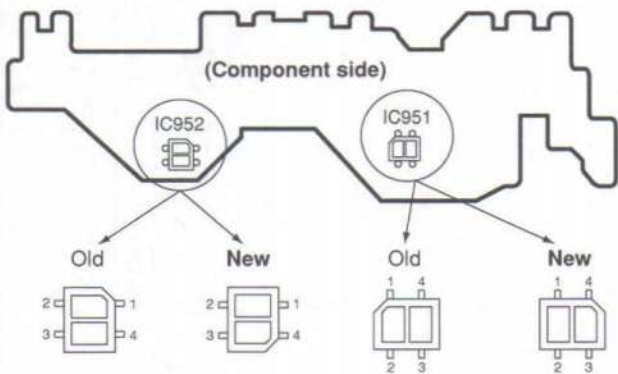



E OPERATION P.C.B.

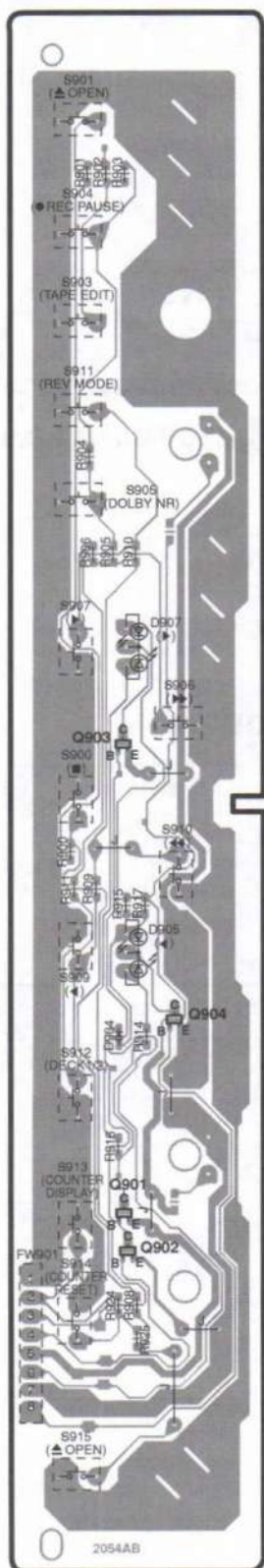

D EARTH TERMINAL P.C.B.



(REP2827B-M)

ELECTRICAL PARTS LOCATION

Ref. No.	Lo. No.	Ref. No.	Lo. No.
D EARTH TERMINAL P.C.B.			
W601	2E	E1	2D
E OPERATION P.C.B.			
Q901	7B	S915	8B
Q902	7B	FW901	7A
Q903	5B	R900	5B
Q904	6B	R901	2B
D904	6B	R902	2B
D905	6B	R903	2B
D907	4B	R904	3B
S900	5B	R905	4B
S901	2B	R906	4B
S903	3B	R908	7B
S904	2B	R909	5B
S905	3B	R910	4B
S906	4B	R911	5B
S907	4B	R914	6B
S909	6B	R915	5B
S910	5B	R916	6B
S911	3B	R917	5B
S912	6B	R924	7B
S913	7B	R925	7B
S914	7B		

■ Wiring Connection Diagram

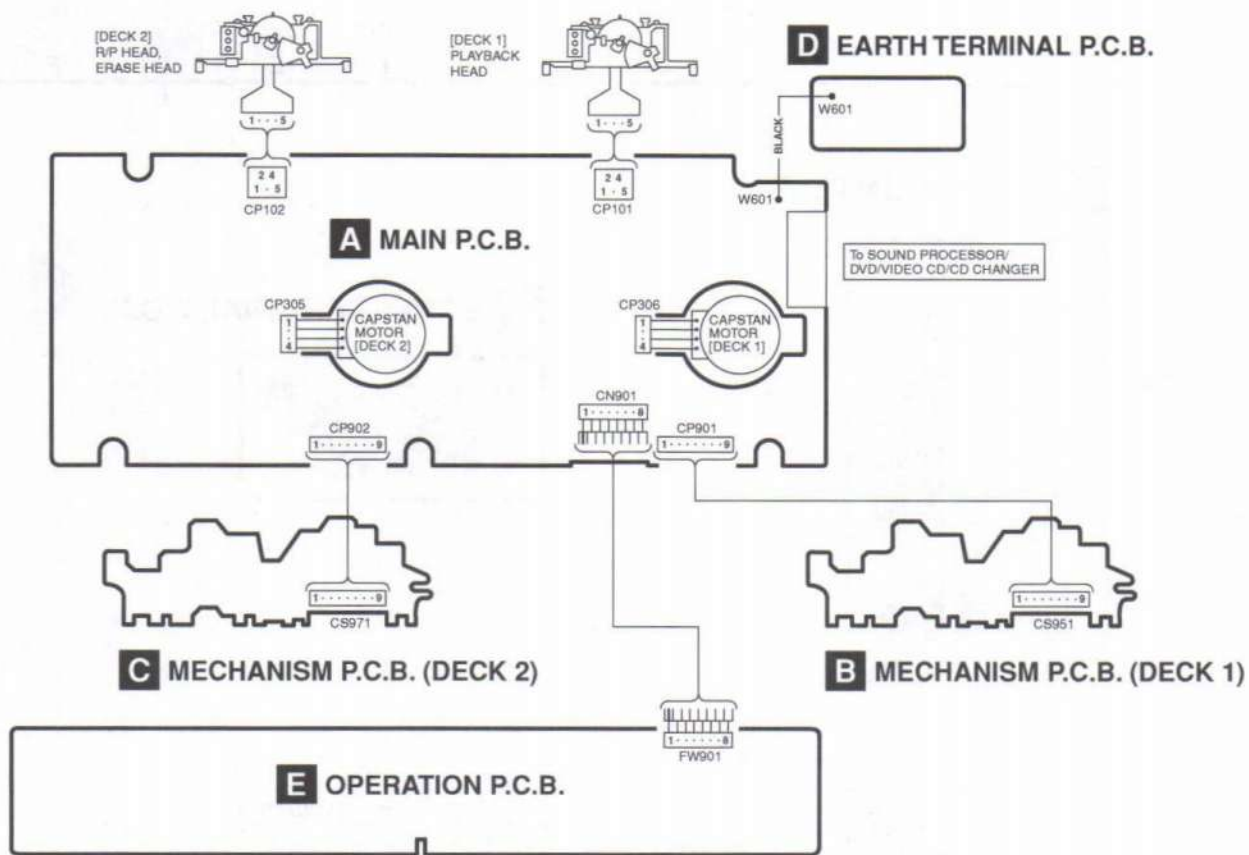

■ Type Illustration of IC's, Transistors and Diodes

 <table border="1" data-bbox="254 1156 485 1234"> <tr><td>CXA1552M-T4</td><td>16PIN</td></tr> <tr><td>MC14066BFEL</td><td>14PIN</td></tr> <tr><td>M38503M2406F</td><td>42PIN</td></tr> </table>	CXA1552M-T4	16PIN	MC14066BFEL	14PIN	M38503M2406F	42PIN	<p>BA7755AF</p> 	<p>CXA1998BQT6</p> 	<p>ON2180RLC1</p> 	<p>2SD1450RSTA</p> 
CXA1552M-T4	16PIN									
MC14066BFEL	14PIN									
M38503M2406F	42PIN									
<p>2SB621ARSTA 2SD592ARSTA</p> 	 <p>2SD1819ARTX 2SD2436STXRA DTA143EUT106 DTC114EUT106 DTC143EUT106 DTC144EUT106</p>	<p>2SC3940AQSTA</p> 	<p>2SD2144STA</p> 	<p>2SJ164QTA 2SJ164RTA</p> 						
<p>MA165TA</p> 	<p>MA4051MTA MA4056MTA</p> 	<p>SML79455C</p> 	<p>MA110TX</p> 							

Terminal Function of IC's

● IC701 (M38503M2406F) : Micro Computer

Pin No.	Terminal Name	I/O	Function
1	V _{CC}	I	Power supply terminal
2	VREF	I	Reference voltage input
3	AV _{SS}	-	GND terminal
4	LMT	O	Muting control signal output
5	PL1	O	DECK 1 solenoid control signal output
6	M1	O	DECK 1 motor drive signal output
7	HALT	I	Power failure detect signal input
8	REQ	I	Serial communication request signal input
9	CS	I	Serial communication complete signal input
10	CLK	O	Serial communication clock signal output
11	DATA OUT	O	Serial communication data signal output
12	DATA IN	I	Serial communication data signal input
13	METAL 2	I	DECK 2 tape detect switch signal (METAL) input
14	CrO ₂ 2	I	DECK 2 tape detect switch signal (CrO ₂) input
15	V _{SS}	-	GND terminal
16	FWD LED	O	LED drive control signal (FWD) output
17	REV LED	O	LED drive control signal (REV) output
18	RESET	I	Reset signal input
19	XIN	I	Clock signal input (8 MHz)
20	XOUT	O	Clock signal output (8 MHz)

Pin No.	Terminal Name	I/O	Function
21	V _{SS}	-	GND terminal
22	CrO ₂ 1	I	DECK 1 tape detect switch signal (CrO ₂) input
23	MODE	I	DECK 1 mechanism switch signal (MODE) input
24	HALF1	I	DECK 1 mechanism switch signal (Half) input
25	TPS	I	TPS signal input
26	A DATA	O	Serial data signal output for IC101
27	A CLK	O	Serial clock signal output for IC 101
28	A LATCH	O	Serial latch signal output for IC 101
29	PL2	O	DECK 2 solenoid control signal output
30	M2	O	DECK 2 motor drive signal output
31	ENC/DEC	O	DOLBY NR record/playback mode select signal output
32	DOLBY ON/OFF	O	DOLBY NR ON/OFF control signal output
33	E CS	-	EEPROM chip select signal output (Not used, open)
34-36	NC	-	Not used, open
37	LED CNT	O	LED color control signal output
38	PHOTO2 T	I	DECK 2 reel pulse detect signal input
39	AD SW	I	DECK 2 mechanism switch signal input (Half, Mode, F.REC.INH., R.REC.INH.)
40	PHOTO1 T	I	DECK 1 reel pulse detect signal input
41	KEY2	I	Operation key signal input 2
42	KEY1	I	Operation key signal input 1

Block Diagram

Notes
 ● Signal line ➔ : Playback signal line
 ➤ : Recording signal line
 ● () indicates pin No. Right channel.

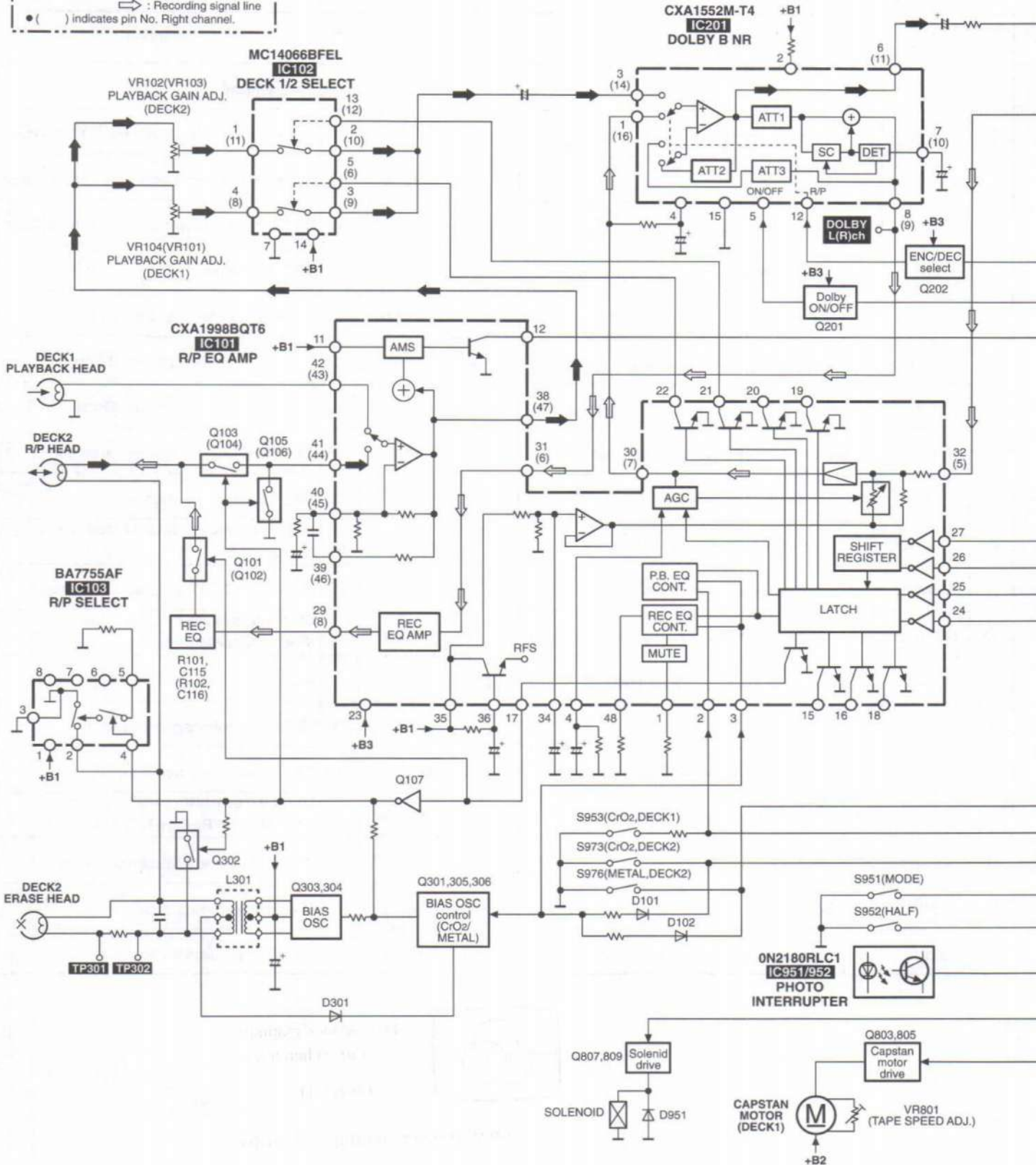

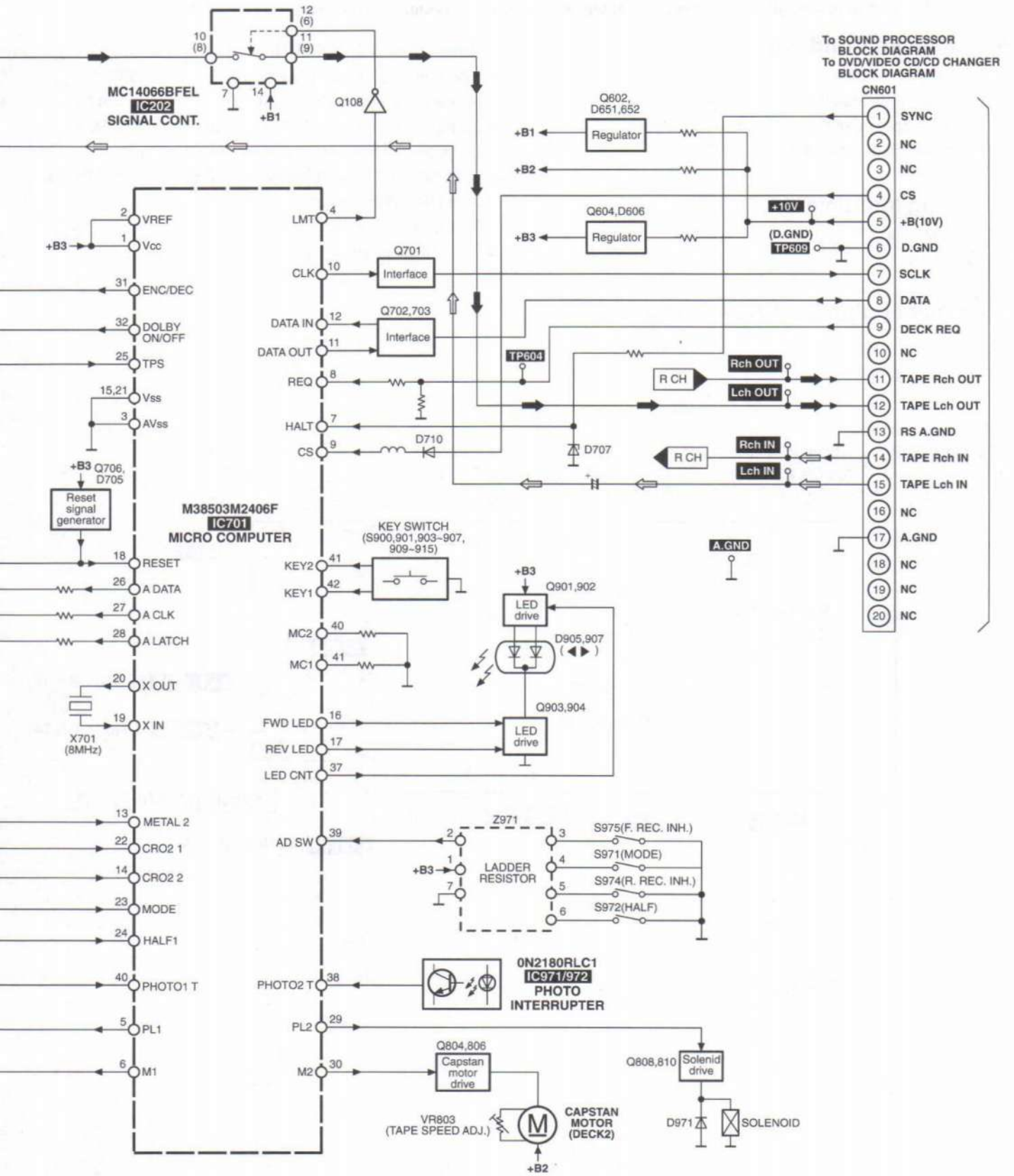

■ Measurements and Adjustments

- This unit RS-DV150 is designed to operate on power supplied from system connected.

Measurement Condition

- Dolby NR switch: OFF
- Make sure heads are clean.
- Make sure capstan and pressure roller are clean.
- Room temperature: $20 \pm 5^{\circ}\text{C}$ ($68 \pm 9^{\circ}\text{F}$)

Measuring instrument

- DC Power Supply
- AF Oscillator

Measurement Condition

- Head azimuth adjustment (8 kHz, -20 dB): QZZCFM
- Tape speed adjustment (3 kHz, -10 dB): QZZCWAT
- Playback gain adjustment (315 Hz, 0 dB): QZZCFM
- Recording/playback frequency response adjustment:
QZZCFM (315 Hz/0 dB, 315Hz/-20dB, 12.5 kHz~63 Hz/-20 dB)
QZZCRA (Normal blank tape)
QZZCRX (CrO₂ blank tape)
QZZCRZ (Metal blank tape)

Adjustment Points and Test Points

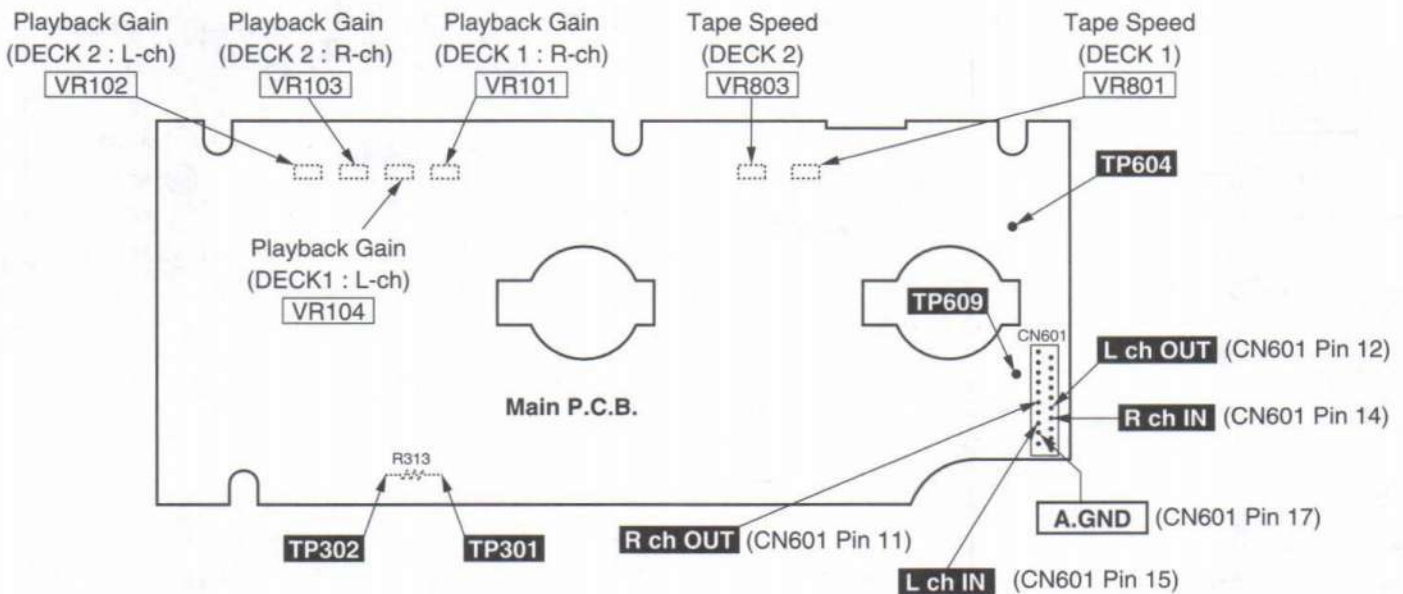

Fig. 1

HEAD AZIMUTH ADJUSTMENT (DECK 1/2)

1. Connect the measuring instrument as shown in Fig. 2.
2. Replace azimuth screws for both forward and reverse direction after removing the screw-locking bond left on the head base.
Fine adjustment of azimuth can not be performed with remaining the bond on the head base.
(Supply part No. of azimuth adjusting screw: **RHD17015**)
3. Playback the azimuth adjustment portion (8 kHz, -20 dB) of test tape (QZZCFM). Adjust the azimuth adjusting screw until the outputs of the L/R-ch are maximized. (Refer to Fig. 3.)
Make sure that the difference in the peak level between the left and right channels does not exceed 0.5 dB.
4. Perform the same adjustment in reverse playback mode.

Check of the level difference forward and reverse directions

5. Playback the playback gain adjustment portion (315 Hz, 0 dB) of test tape (QZZCFM). Check if level difference between forward and reverse direction is within 1.5 dB.
6. After the adjustment, apply screwlock to the azimuth adjusting screw.

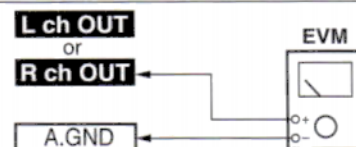

Fig. 2

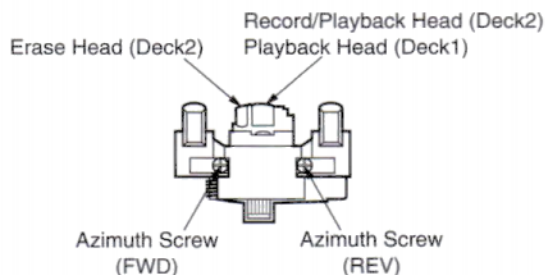

Fig. 3

TAPE SPEED ADJUSTMENT (DECK 1/2)

Note: When connecting the unit to other system components for testing, short the section between the test points **TP609** and **TP604** and turn on the entire system. (The unit is set to the TEST mode, and either the DECK 1 or DECK 2 indicators will blink.)

Normal speed (Standard value: 3000 ± 45 Hz)

1. Playback the middle portion of the test tape (QZZCWAT).
2. Adjust Deck 1 = **VR801** and Deck 2 = **VR803** for the output value shown below. (Refer to Fig. 1)

Adjustment target: 3000 ± 15 Hz (NORMAL speed)

Standard value: 3000 ± 45 Hz (NORMAL speed)

Note: When connecting the unit to other system components, disconnect the short between the test points **TP609** and **TP604**.

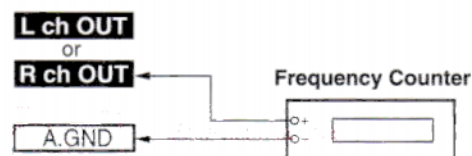

Fig. 4

PLAYBACK GAIN ADJUSTMENT (DECK 1/2)

1. Find the start of the 315 Hz/0 dB section of the test tape (QZZCFM), insert the tape into Deck 1 and 2, and play it back (FWD)
2. Adjust Deck 2 : **VR102** (L-ch) [**VR103** (R-ch)] and Deck 1 : **VR104** (L-ch) [**VR101** (R-ch)] so that the output is within the standard value. (Refer to Fig. 1.)

Standard value : 265 mV ~ 300 mV



Fig. 5

ERASE CURRENT CONFIRMATION (DECK 2)

1. Insert the blank tape into Deck 2, and press the REC PAUSE button.
2. Check if the output at this time between the erase current confirmation point **TP301** and **TP302** (the output on both edged of R313) is within the standard value. (Refer to Fig. 6.)

Standard value	EVM reading
Normal tape : 85 ± 25 mA	(85 ± 25 mV)
CrO ₂ tape : 150 ± 25 mA	(150 ± 25 mV)
Metal tape : 185 ± 25 mA	(185 ± 25 mV)

Note: The test tape is not required when confirming the erase current.

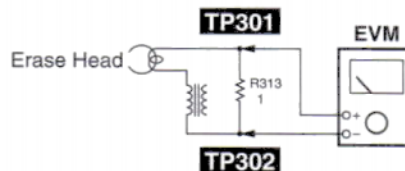

Fig. 6

Playback frequency response check (DECK 1/2)

Playback the 315 Hz/-20 dB and 12.5 kHz to 63 Hz/-20 dB sections of the test tape (QZZCFM) and then, using the 315 Hz/-20 dB playback output as a reference (0 dB), confirm that the playback frequency response is within the range shown in Fig. 8.

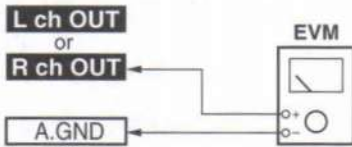

Fig. 7

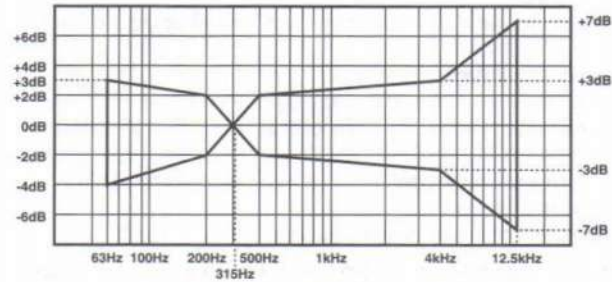

Fig. 8

Recording/playback frequency response and gain check (DECK 2)

Normal tape check

1. Insert a Normal-type blank tape (QZZCRA) into Deck 2.
2. Record signals at 50 Hz, 100 Hz, 200 Hz, 500 Hz, 1 kHz, 2 kHz, 10 kHz and 12.5 kHz (28 mV).
3. Set the playback frequency of the recorded signals at 1 kHz as the reference response (0 dB).
4. Playback the recorded signals to confirm that the output is within the range of the overall frequency response shown in Fig. 10.

CrO₂/Metal tape check

5. Repeat steps 2 to 4 for each tape and confirm that the output for each is within the range of the overall frequency response shown in Fig. 11.

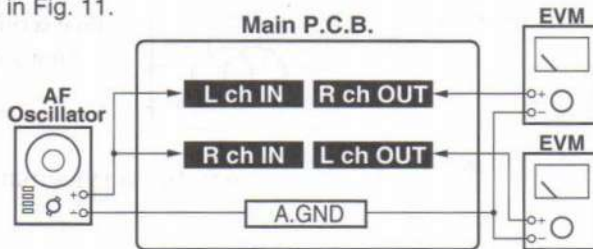
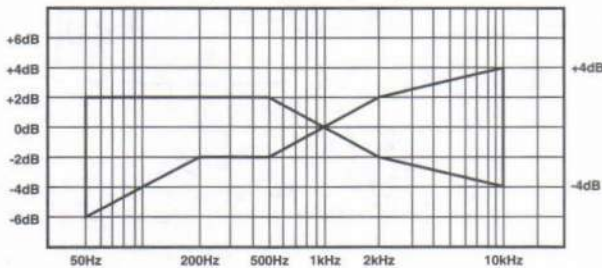

Fig. 9

Normal Tape Overall frequency response chart

(Dolby NR OFF)



(Dolby NR ON)

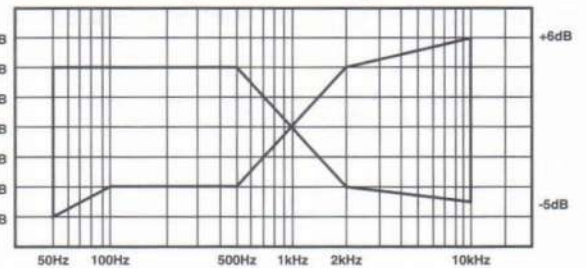
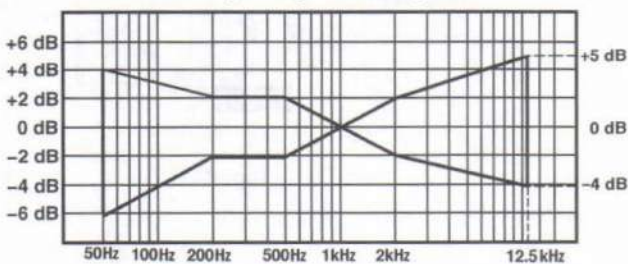

Fig. 10

CrO₂ and Metal Tape Overall frequency response chart

(Dolby NR OFF)



(Dolby NR ON)

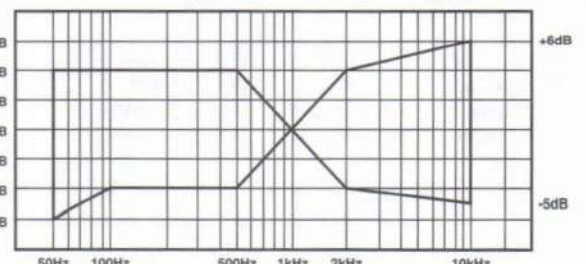

Fig. 11

Replacement Parts List

Notes: * Important safety notice:
 Components identified by Δ mark have special characteristics important for safety.
 Furthermore, special parts which have purposes of fire-retardant (resistors), high-quality sound (capacitors), low-noise (resistors), etc. are used.
 When replacing any of components, be sure to use only manufacture's specified parts shown in the parts list.
 * ALL parts are supplied by MESA.

Ref.No.	Part No.	Part Name & Description	Pcs	Remarks
1	RKM0392-S	CABINET	1	
2	RHD30007-S	SCREW	4	
3	XTBS3+10JFZ1	SCREW	2	
5	RKA0105-K	RUBBER	3	
6	RKA0106-N	FOOT RING	4	
7	RMN0539	CONNECTOR HOLDER	1	
8	RDG0129-1	GEAR	2	
9	REX0989	WIRE ASS'Y	1	
10	RGB0022-A	PANASONIC BADGE	1	
11	RGK1131-S	ORNAMENT(L)	1	
12	RGK1132-S	ORNAMENT(R)	1	
13	RGL0441-Q	PANEL LIGHT	1	
14	RJR0113	CONNECTOR	2	
15	RKF0462-K2	CASSETTE HOLDER(L)	1	
16	RKF0463-K2	CASSETTE HOLDER(R)	1	
17	RKF0587A-S	CASSETTE LID(L)	1	
18	RKF0588-S	CASSETTE LID(R)	1	
19	RKW0577-Q	CASSETTE WINDOW(L)	1	
20	RKW0578-Q	CASSETTE WINDOW(R)	1	
21	RMB0474	SPRING	2	
22	RMQ0577A-3	FRAME	1	
23	RUS757ZA	SPRING	4	
24	RYP0913-S	FRONT PANEL	1	
25	XTBS26+8J	SCREW	7	
26	XTB3+10JFZ	SCREW	5	
27	XTBS3+8JFZ1	SCREW	3	
101	RED0037	HEAD BLOCK(R/P)	1	
101-1	RHD17015	SCREW	2	
102	RED0038	HEAD BLOCK(PB)	1	
102-1	RHD17015	SCREW	2	
103	RDG0300	REEL TABLE ASS'Y	4	
104	RDG0301	GEAR	2	
105	RDK0026	GEAR	2	
107	RDV0033-4	BELT1	2	
108	RDV0034	BELT2	2	
110	RUW147ZA	SPRING	2	
111	RMB0400	SPRING	4	
112	RMB0403	SPRING	2	
113	RMB0404	SPRING	2	
114	RMB0406	SPRING	2	
115	RMB0408	SPRING	2	
116	RML0370-J	LEVER	2	
117	RML0371	LEVER	2	
118	RML0372	LEVER	2	
119	RML0374	LEVER	2	
120	RMM0131	ROD	2	
121	RMM0133	ROD	2	
122	RMQ0519	RELL CAP	4	
123	RMS0398-1	SHAFT	2	
124	RSJ0003	PLUNGER ASS'Y	2	
125	RUS609ZC	SPRING	2	
126	RXF0049	FLY WHEEL ASS'Y	2	
127	RXF0050	FLY WHEEL ASS'Y	2	
128	RXG0040	GEAR	4	
129	RMK0283	SUB CHASSIS	1	
130	RXL0124	PINCH ROLLER ASS'Y	2	
130-1	RMB0401	SPRING	2	
131	RXL0125	PINCH ROLLER ASS'Y	2	
131-1	RMB0402	SPRING	2	
132	RXL0126	ARM GEAR	2	
133	RXQ0412	CHASSIS ASS'Y	2	
133-1	RMB0405	SPRING	2	
134	REM0055-1	MOTOR ASS'Y	2	
135	RHD26022	SCREW	4	

Ref.No.	Part No.	Part Name & Description	Pcs	Remarks
136	XTW2+5L	SCREW	4	
137	XTW26+10S	SCREW	6	
138	XYC2+JF17	SCREW	2	
140	RFKJSCH770EK	MAIN CHASSIS ASS'Y	1	
C101-04	ECUV1H681KBN	50V 680P	4	
C109,10	ECQB1H183JF3	50V 0.018U	2	
C111,12	ECEA0JKS470	6.3V 47U	2	
C113,14	ECEA1HKS2R2	50V 2.2U	2	
C115,16	ECUV1H471KBN	50V 470P	2	
C117,18	ECUV1H331KBN	50V 330P	2	
C119,20	ECEA1HKS010	50V 1U	2	
C123,24	ECEA1EKS4R7	25V 4.7U	2	
C125,26	ECUV1H332KBN	50V 3300P	2	
C129	ECEA1AKS220	10V 22U	1	
C130	ECEA1CKS101	16V 100U	1	
C131-34	ECUV1H471KBN	50V 470P	4	
C135	RCE1CKA100BG	16V 10U	1	
C136	ECEA1HKS010	50V 1U	1	
C137	ECEA1HKS0R1	50V 0.1U	1	
C138	ECUV1E473KBN	25V 0.047U	1	
C139	ECEA0JKS470	6.3V 47U	1	
C140	RCE1CKA100BG	16V 10U	1	
C141	ECEA1HKS010	50V 1U	1	
C142	ECUV1E104ZFN	25V 0.1U	1	
C143,44	ECUV1H471KBN	50V 470P	2	
C150	RCE1AKA101BG	10V 100U	1	
C203,04	ECEA1EKS4R7	25V 4.7U	2	
C205,06	ECEA1HKS010	50V 1U	2	
C207,08	ECUV1H271KBN	50V 270P	2	
C211,12	ECUV1H152KBN	50V 1500P	2	
C213,14	ECEA1EKS4R7	25V 4.7U	2	
C215,16	RCE1CKA100BG	16V 10U	2	
C217,18	ECEA1HKS0R1	50V 0.1U	2	
C219	ECEA1CKS101	16V 100U	1	
C220	RCE1ARC471BG	10V 470U	1	
C221,22	ECEA1HKAR68B	50V 0.68U	2	
C223	ECEA1EKS4R7	25V 4.7U	1	
C225,26	ECEA1EKS4R7	25V 4.7U	2	
C239,40	ECUV1H681KBN	50V 680P	2	
C241	ECUV1H103KBN	50V 0.01U	1	
C301	ECA1CM471	16V 470U	1	
C302	ECEA2AN2R2SB	100V 2.2U	1	
C303	ECQP2E682JZT	250V 6800P	1	
C304	ECEA1CKS101	16V 100U	1	
C305	ECEA1HKS0R1	50V 0.1U	1	
C306	ECQB1H393JF3	50V 0.039U	1	
C307	ECUV1H102KBN	50V 1000P	1	
C308	ECUV1H332KBN	50V 3300P	1	
C309	ECEA0JKS470	6.3V 47U	1	
C310,11	ECUV1H103KBN	50V 0.01U	2	
C323	ECUV1H102KBN	50V 1000P	1	
C602	ECA1CM221	16V 220U	1	
C603	RCE1CKA470BG	16V 47U	1	
C604	ECUV1E103ZFN	25V 0.01U	1	
C605	ECA1CM221	16V 220U	1	
C701	ECUV1H103KBN	50V 0.01U	1	
C702	ECEA0JKS101	6.3V 100U	1	
C705	ECUV1E103ZFN	25V 0.01U	1	
C706	RCE1HKA3R3BG	50V 3.3U	1	
C707	ECUV1E103ZFN	25V 0.01U	1	
CN601	RJS2A5520-1	CONNECTOR(20P)	1	
CN901	RJS8T6ZA	CONNECTOR(8P)	1	
CP101,02	RJS1A6805	CONNECTOR(5P)	2	
CP901,02	RJT071K09A	CONNECTOR(9P)	2	
CS951	RJU071H09M	CONNECTOR(9P)	1	
CS971	RJU071H09M	CONNECTOR(9P)	1	
D101,02	MA110TX	DIODE	2	
D301	MA110TX	DIODE	1	
Δ D606	MA4056M	DIODE	1	
D651,52	MA165	DIODE	2	
D701	MA110TX	DIODE	1	
D705,06	MA110TX	DIODE	2	
D707	MA4051M	DIODE	1	

Ref.No.	Part No.	Part Name & Description	Pcs	Remarks
D708-10	MA110TX	DIODE	3	
D904	MA110TX	DIODE	1	
D905	SML79455C	LED	1	
D907	SML79455C	LED	1	
D951	MA165	DIODE	1	
D971	MA165	DIODE	1	
IC101	CXA1998BQT6	IC	1	
IC102	MC14066BFEL	IC	1	
IC103	BA7755AF	IC	1	
IC201	CXA1552M-T4	IC	1	
IC202	MC14066BFEL	IC	1	
IC701	M38503M2406F	IC	1	
IC951,52	ON2180RLC1	IC	2	
IC971,72	ON2180RLC1	IC	2	
L201,02	ELELN103KA	COIL	2	
L301	RL08B006-K	COIL	1	
L302	RLQZB101KT-D	COIL	1	
L701	RLQA100JT1-Y	COIL	1	
L702	RLBN102V-Y	COIL	1	
PCB1	REP2827B-M	MAIN P.C.B.	1	(RTL)
Q101,02	2SJ164RTA	TRANSISTOR	2	
Q103,04	2SJ164QTA	TRANSISTOR	2	
Q105,06	2SD1819ARTX	TRANSISTOR	2	
Q107	DTA143EUT106	TRANSISTOR	1	
Q108	DTC143EUT106	TRANSISTOR	1	
Q201,02	DTA143EUT106	TRANSISTOR	2	
Q301	2SD1819ARTX	TRANSISTOR	1	
Q302	2SD2436STXRA	TRANSISTOR	1	
Q303,04	2SD1450S	TRANSISTOR	2	
Q305,06	DTC144EUT106	TRANSISTOR	2	
△ Q602	2SD2144S	TRANSISTOR	1	
△ Q604	2SC3940AQSTA	TRANSISTOR	1	
Q701-03	2SD1819ARTX	TRANSISTOR	3	
Q706	DTC114EUT106	TRANSISTOR	1	
Q803,04	2SD592AR	TRANSISTOR	2	
Q805,06	DTA143EUT106	TRANSISTOR	2	
Q807,08	2SB621A-R	TRANSISTOR	2	
Q809,10	DTC143EUT106	TRANSISTOR	2	
Q901	DTA143EUT106	TRANSISTOR	1	
Q902-04	DTC143EUT106	TRANSISTOR	3	
R101,02	ERJ6GEYJ562V	1/10W 5.6K	2	
R103,04	ERJ6GEYJ104V	1/10W 100K	2	
R105,06	ERJ6GEYJ334V	1/10W 330K	2	
R107,08	ERJ6GEYJ103V	1/10W 10K	2	
R109,10	ERJ6GEYJ102Z	1/10W 1K	2	
R111	ERJ6GEYJ820V	1/10W 82	1	
R112	ERJ8GEYJ820V	1/8W 82	1	
R113	ERJ6GEYJ123V	1/10W 12K	1	
R114	ERJ6GEYJ273V	1/10W 27K	1	
R117	ERJ6GEYJ102Z	1/10W 1K	1	
R118,19	ERDS2FJ220	1/4W 22	2	
R120	ERJ6GEYJ104V	1/10W 100K	1	
R121,22	ERJ6GEYJ103V	1/10W 10K	2	
R125	ERJ6GEYJ104V	1/10W 100K	1	
R126	ERJ6GEYJ223V	1/10W 22K	1	
R127	ERJ6GEYJ472V	1/10W 4.7K	1	
R130	ERJ6GEYJ475V	1/10W 4.7M	1	
R131	ERJ6GEYJ334V	1/10W 330K	1	
R132	ERJ6GEYJ273V	1/10W 27K	1	
R133	ERJ6GEYJ333V	1/10W 33K	1	
R134	ERJ6GEYJ392V	1/10W 3.9K	1	
R135	ERJ6GEYJ682V	1/10W 6.8K	1	
R136,37	ERJ6GEYJ222V	1/10W 2.2K	2	
R138	ERJ6GEYJ472V	1/10W 4.7K	1	
R139,40	ERJ6GEYJ473V	1/10W 47K	2	
R141	ERJ8GEYJ101V	1/8W 100	1	
R142	ERJ6GEYJ101V	1/10W 100	1	
R143	ERDS2FJ101	1/4W 100	1	
R144	ERJ6GEYJ101V	1/10W 100	1	
R147-50	ERJ6GEYJ562V	1/10W 5.6K	4	
R151,52	ERJ6GEYJ104V	1/10W 100K	2	
R153,54	ERJ6GEYJ681V	1/10W 680	2	
R157,58	ERJ6GEYJ223V	1/10W 22K	2	
R207,08	ERJ6GEYJ473V	1/10W 47K	2	

Ref.No.	Part No.	Part Name & Description	Pcs	Remarks
R209,10	ERJ6GEYJ102Z	1/10W 1K	2	
R211,12	ERJ6GEYJ103V	1/10W 10K	2	
R213,14	ERJ6GEYJ302V	1/10W 3K	2	
R215,16	ERJ6GEYJ123V	1/10W 12K	2	
R217,18	ERJ6GEYJ222V	1/10W 2.2K	2	
R219	ERJ6GEYJ183V	1/10W 18K	1	
R220	ERDS2FJ220	1/4W 22	1	
R221,22	ERJ6GEYJ101V	1/10W 100	2	
R223,24	ERJ6GEYJ103V	1/10W 10K	2	
R225,26	ERJ6GEYJ473V	1/10W 47K	2	
R230,31	ERJ6GEYJ102Z	1/10W 1K	2	
R232	ERJ6GEYJ103V	1/10W 10K	1	
R233,34	ERJ6GEYJ101V	1/10W 100	2	
R237	ERDS2FJ220	1/4W 22	1	
R301	ERJ6GEYJ103V	1/10W 10K	1	
R302	ERJ6GEYJ182V	1/10W 1.8K	1	
R303	ERJ6GEYJ222V	1/10W 2.2K	1	
R304	ERJ6GEYJ153V	1/10W 15K	1	
R305	ERJ6GEYJ183V	1/10W 18K	1	
R306	ERJ6GEYJ333V	1/10W 33K	1	
△ R307	ERDS1FJ2R2	1/2W 2.2	1	
R308	ERJ6GEYJ102Z	1/10W 1K	1	
R309-11	ERJ6GEYJ472V	1/10W 4.7K	3	
R313	ERDS2FJ1R0	1/4W 1	1	
△ R602	ERQ16NKWR33E	1/6W 0.33	1	
△ R603	ERD2FCG100	1/4W 10	1	
R604	ERJ6GEYJ331V	1/10W 330	1	
R606	ERJ6GEYJ152V	1/10W 1.5K	1	
R609	ERDS2FJ101	1/4W 100	1	
△ R630	ERQ16NKWR33E	1/6W 0.33	1	
R632	ERDS2FJ473	1/4W 47K	1	
R701,02	ERJ6GEYJ103V	1/10W 10K	2	
R703	ERJ6GEYJ562V	1/10W 5.6K	1	
R704	ERJ6GEYJ472V	1/10W 4.7K	1	
R705	ERJ6GEYJ473V	1/10W 47K	1	
R708	ERJ6GEYJ472V	1/10W 4.7K	1	
R710	ERJ6GEYJ102Z	1/10W 1K	1	
R711	ERJ6GEYJ104V	1/10W 100K	1	
R712	ERJ8GEYJ683V	1/8W 68K	1	
R718	ERJ8GEYJ683V	1/8W 68K	1	
R721	ERJ6GEYJ472V	1/10W 4.7K	1	
R722	ERJ6GEYJ101V	1/10W 100	1	
R723,24	ERJ6GEYJ102Z	1/10W 1K	2	
R725,26	ERJ6GEYJ222V	1/10W 2.2K	2	
R727	ERJ6GEYJ472V	1/10W 4.7K	1	
R728	ERJ6GEYJ103V	1/10W 10K	1	
R729	ERJ6GEYJ472V	1/10W 4.7K	1	
R730	ERJ6GEYJ222V	1/10W 2.2K	1	
R732	ERJ6GEYJ104V	1/10W 100K	1	
R735	ERJ6GEYJ472V	1/10W 4.7K	1	
R736	ERJ6GEYJ103V	1/10W 10K	1	
R737	ERJ8GEYJ103V	1/8W 10K	1	
R738	ERJ6GEYJ102Z	1/10W 1K	1	
R741	ERJ6GEYJ223V	1/10W 22K	1	
R743	ERJ6GEYJ473V	1/10W 47K	1	
R744	ERJ6GEYJ102Z	1/10W 1K	1	
R745	ERJ6GEYJ101V	1/10W 100	1	
R747	ERJ8GEYJ102V	1/8W 1K	1	
R802	ERJ6GEYJ561V	1/10W 560	1	
R803	ERJ6GEYJ103V	1/10W 10K	1	
R805	ERJ6GEYJ392V	1/10W 3.9K	1	
R806	ERJ6GEYJ103V	1/10W 10K	1	
R808	ERJ6GEYJ392V	1/10W 3.9K	1	
R810,11	ERJ6GEYJ103V	1/10W 10K	2	
R812	ERJ6GEYJ561V	1/10W 560	1	
R813,14	ERJ6GEYJ471V	1/10W 470	2	
R818	ERDS2FJ2R2	1/4W 2.2	1	
R820	ERDS2FJ2R2	1/4W 2.2	1	
R823,24	ERJ6GEYJ561V	1/10W 560	2	
R900	ERJ8GEYJ821V	1/10W 820	1	
R901	ERJ8GEYJ102Z	1/10W 1K	1	
R902	ERJ6GEYJ122V	1/10W 1.2K	1	
R903	ERJ6GEYJ152V	1/10W 1.5K	1	
R904	ERJ6GEYJ182V	1/10W 1.8K	1	
R905	ERJ6GEYJ222V	1/10W 2.2K	1	
R906	ERJ6GEYJ332V	1/10W 3.3K	1	
R908	ERJ6GEYJ122V	1/10W 1.2K	1	
R909	ERJ6GEYJ152V	1/10W 1.5K	1	

■ Mechanism Parts Location

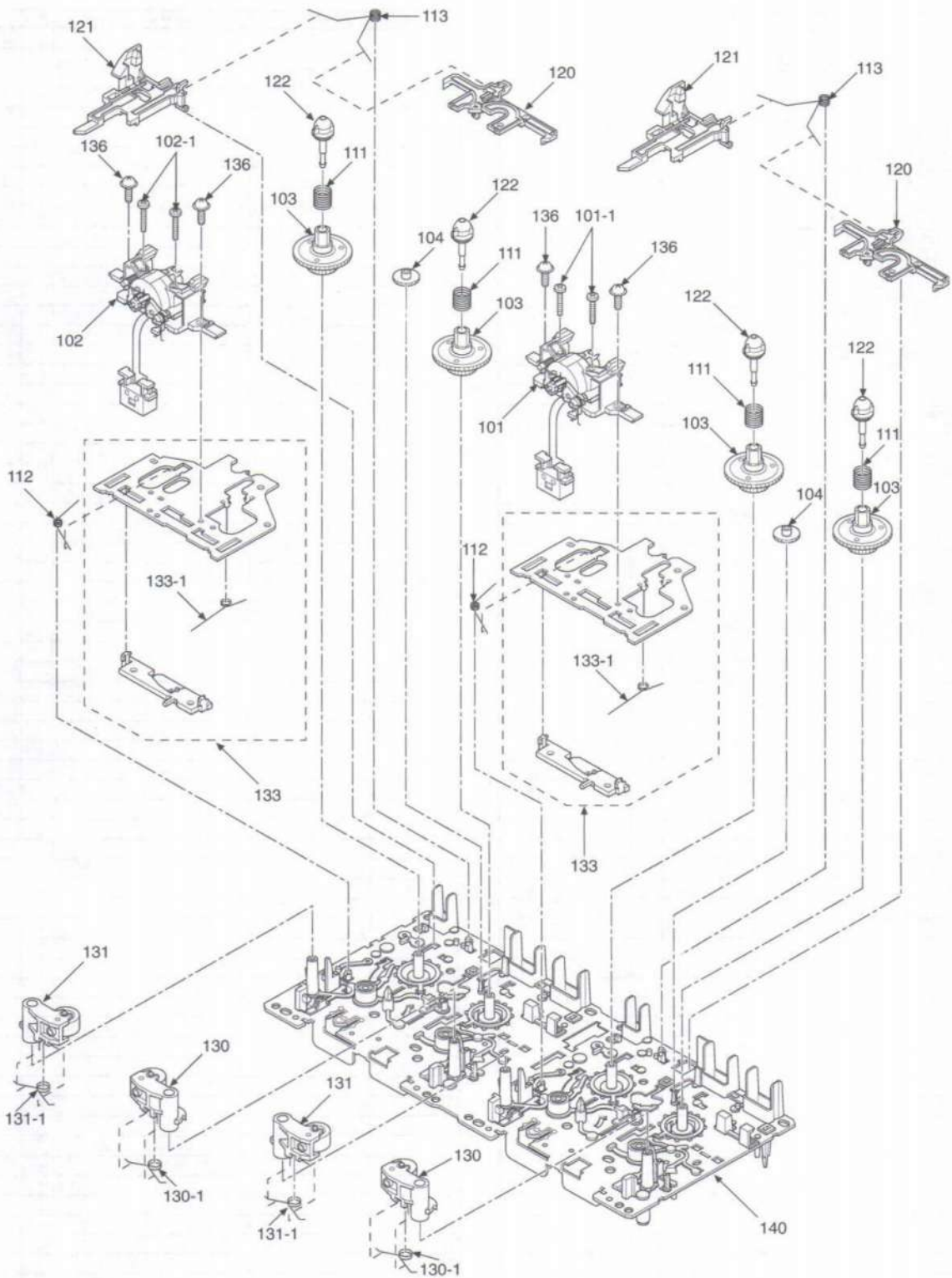

Ref.No.	Part No.	Part Name & Description	Pcs	Remarks
101	RED0037	HEAD BLOCK(R/P)	1	
101-1	RHD17015	SCREW	2	
102	RED0038	HEAD BLOCK(P/B)	1	
102-1	RHD17015	SCREW	2	
103	RDG0300	REEL TABLE ASS'Y	4	
104	RDG0301	GEAR	2	
105	RDK0026	GEAR	2	
107	RDV0033-4	BELT1	2	
108	RDV0034	BELT2	2	
110	RUW147ZA	SPRING	2	
111	RMB0400	SPRING	4	

Ref.No.	Part No.	Part Name & Description	Pcs	Remarks
112	RMB0403	SPRING	2	
113	RMB0404	SPRING	2	
114	RMB0406	SPRING	2	
115	RMB0408	SPRING	2	
116	RML0370-J	LEVER	2	
117	RML0371	LEVER	2	
118	RML0372	LEVER	2	
119	RML0374	LEVER	2	
120	RMM0131	ROD	2	
121	RMM0133	ROD	2	
122	RMQ0519	REEL CAP	4	

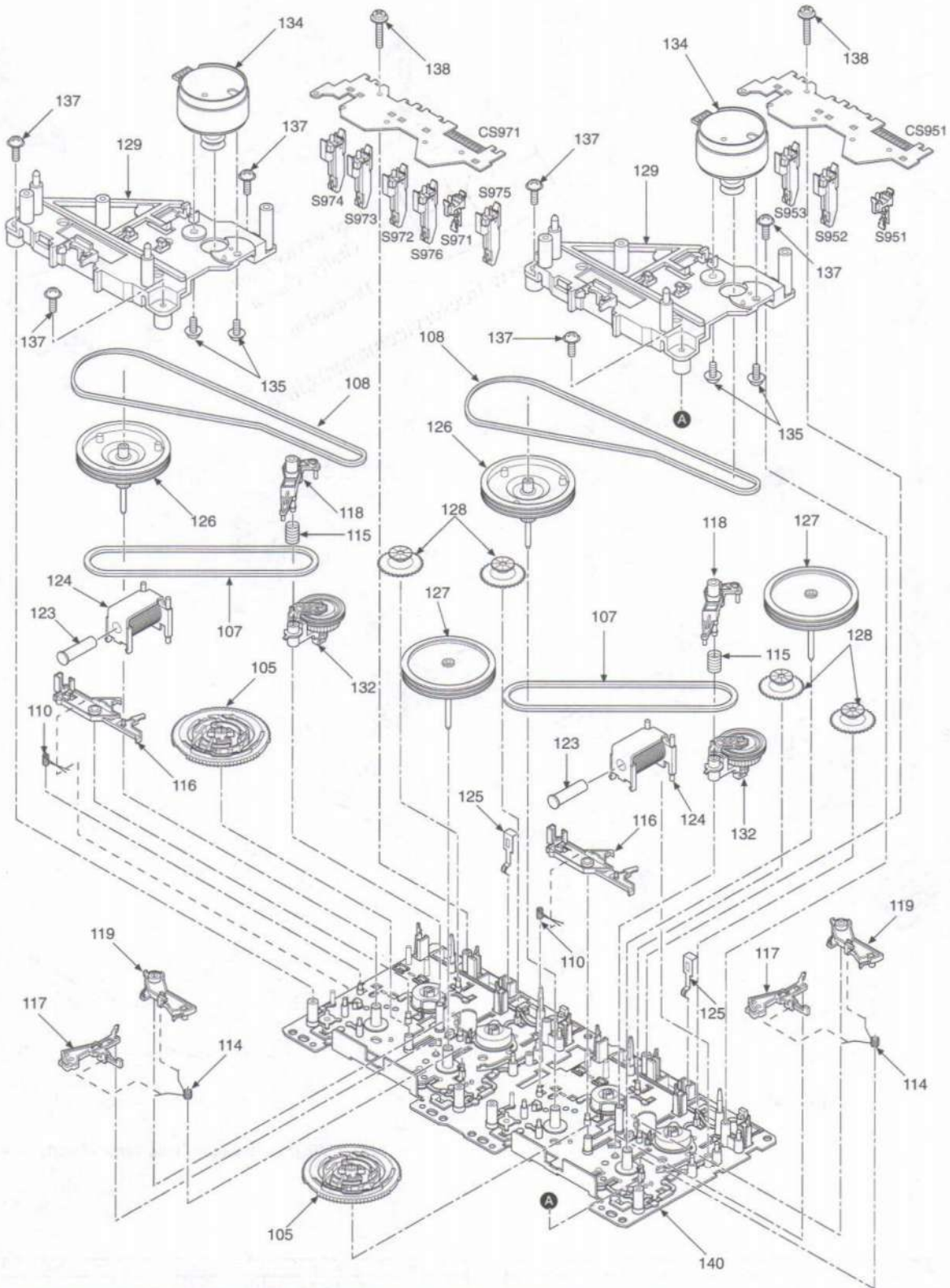

Ref.No.	Part No.	Part Name & Description	Pcs	Remarks
123	RMS0398-1	SHAFT	2	
124	RSJ0003	PLUNGER ASSY	2	
125	RUS6092C	SPRING	2	
126	RXF0049	FLY WHEEL ASSY	2	
127	RXF0050	FLY WHEEL ASSY	2	
128	RXG0040	GEAR	4	
129	RMK0283	SUB CHASSIS	1	
130	RXL0124	PINCH ROLLER ASSY	2	
130-1	RMB0401	SPRING	2	
131	RXL0125	PINCH ROLLER ASSY	2	
131-1	RMB0402	SPRING	2	

Ref.No.	Part No.	Part Name & Description	Pcs	Remarks
132	RXL0126	ARM GEAR	2	
133	RXQ0412	CHASSIS ASSY	2	
133-1	RMB0405	SPRING	2	
134	REM0055-1	MOTOR ASSY	2	
135	RHD26022	SCREW	4	
136	XTW2+5L	SCREW	4	
137	XTW26+10S	SCREW	6	
138	XYC2+JF17	SCREW	2	
140	RFKJSCH770EK	MAIN CHASSIS ASSY	1	

■ Cabinet Parts Location

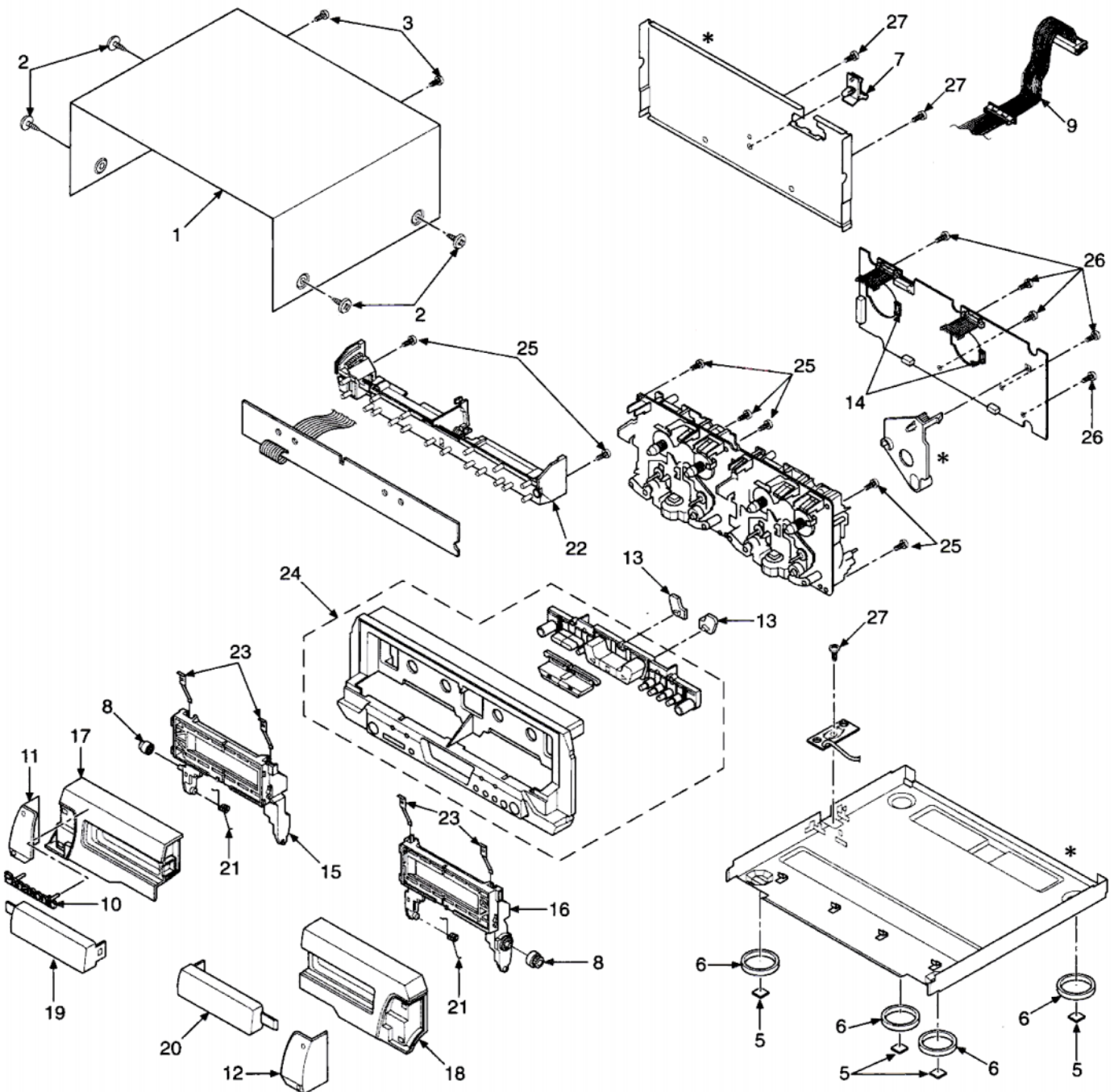

Note: We do not supply those items of parts marked*.

Ref.No.	Part No.	Part Name & Description	Pcs	Remarks
1	RKM0392-S	CABINET	1	
2	RHD30007-S	SCREW	4	
3	XTBS3+10JFZ1	SCREW	2	
5	RKA0105-K	RUBBER	3	
6	RKA0106-N	FOOT RING	4	
7	RMN0539	CONECTOR HOLDER	1	
8	RDG0129-1	GEAR	2	
9	REX0989	WIRE ASS'Y	1	
10	RGB0022-A	PANASONIC BADGE	1	
11	RGK1131-S	ORNAMENT(L)	1	
12	RGK1132-S	ORNAMENT(R)	1	
13	RGL0441-Q	PANEL LIGHT	1	
14	RJR0113	CONNECTOR	2	

Ref.No.	Part No.	Part Name & Description	Pcs	Remarks
15	RKF0462-K2	CASSETTE HOLDER(L)	1	
16	RKF0463-K2	CASSETTE HOLDER(R)	1	
17	RKF0587A-S	CASSETTE LID(L)	1	
18	RKF0588-S	CASSETTE LID(R)	1	
19	RKW0577-Q	CASSETTE WINDOW(L)	1	
20	RKW0578-Q	CASSETTE WINDOW(R)	1	
21	RMB0474	SPRING	2	
22	RMQ0577A-3	FRAME	1	
23	RUS757ZA	SPRING	4	
24	RYP0913-S	FRONT PANEL	1	
25	XTBS26+8J	SCREW	7	
26	XTB3+10JFZ	SCREW	5	
27	XTBS3+8JFZ1	SCREW	3	

Service Manual

Stereo Cassette Deck

Cassette Deck
RS-DV150

Please file and use this manual together with the service manual for Model No. RS-DV150, Order No. AD9906139C1.

- Notes:**
- This simplified service manual is provided to indicate the differences between the original No. RS-DV150 (PP) and the subsequent model No. RS-DV150 (EG).
 - All parts are supplied by MESA.

Colour

(S) Silver Type

Area

(EG) Europe, Middle East, South Africa, Oceania.

■ Replacement Parts List

Ref. No.	Change of Parts No.		Part Name & Description	Remarks
	(PP)	→ (EG)		
CABINET PART(S)				
9	REX0989	REX0966	WIRE ASS'Y	
10	RGB0022-A	RGB0025-A	TECHNICS BADGE	

⚠ WARNING

This service information is designed for experienced repair technicians only and is not designed for use by the general public. It does not contain warnings or cautions to advise non-technical individuals of potential dangers in attempting to service a product. Products powered by electricity should be serviced or repaired only by experienced professional technicians. Any attempt to service or repair the product or products dealt with in this service information by anyone else could result in serious injury or death.

Technics®

© 1999 Matsushita Electric Industrial Co., Ltd.
All rights reserved. Unauthorized copying and distribution is a violation of law.

Printed in Japan
F990608000HH/YI